



INTER  
STORES

Deliverable

International Innovation Network  
for the Development of  
Cost- and Environmentally  
Efficient Seasonal Thermal  
Energy Storages

### **D3.4 – Concepts for Innovative sTES**



Funded by  
the European Union

Project funded by



Schweizerische Eidgenossenschaft  
Confédération suisse  
Confederazione Svizzera  
Confederaziun svizra

Swiss Confederation

Federal Department of Economic Affairs,  
Education and Research EAER  
State Secretariat for Education,  
Research and Innovation SERI

Grant Agreement Number	101136100	Acronym	INTERSTORES	
Full Title	International Innovation Network for the Development of Cost- and Environmentally Efficient Seasonal Thermal Energy Storages			
Start Date	01/01/2024	Duration	48 months	
Call	HORIZON-CL5-2023-D3-01			
Topic	HORIZON-CL5-2023-D3-01-14			
Funding Scheme	Horizon Europe Research and Innovation Programme			
Type of action	HORIZON Innovation Actions			
Project URL	<a href="https://interstores.eu/">https://interstores.eu/</a>			
Social Media	X	<a href="https://twitter.com/InterstoresEU">https://twitter.com/InterstoresEU</a>		
	Flickr	<a href="https://www.flickr.com/people/199918844@N06/">https://www.flickr.com/people/199918844@N06/</a>		
	LinkedIn	<a href="https://www.linkedin.com/showcase/interstores/">https://www.linkedin.com/showcase/interstores/</a>		
	YouTube	<a href="https://www.youtube.com/@InterstoresEU">https://www.youtube.com/@InterstoresEU</a>		
Work Package	WP3 - Storage			
Deliverable	D3.4 – Concepts for Innovative sTES			
Deliverable Type	R - Document, report			
Dissemination Level	PU – Public, fully open, e.g., web			
Date of Delivery	Contractual	31/12/2024	Actual	31/12/2024
Lead Beneficiary	AIT Austrian Institute of Technology (AIT)			
Author(s)/ Organisation(s)	Abdulrahman Dahash/AIT, Christoph Bott/MLU, Shariq Akbar/THI, Simon Müller/THI			
Contributor(s)	Fabrizia Giordano (AIT), Ahmed Serageldin (AIT), David Hoffmann (MLU), David Schmitt (THI), Tobias Schrag (THI), Markku Hagström (GTK), Sami Vallin (GTK), Kati Ahlqvist (GTK), Kimmo Korhonen (GTK), Teppo Arola (GTK), Peter Bayer (MLU)			

## Document Revision History

Version	Issue Date	Stage	Modified by	Changes
1	19/11/2024	Draft	Dahash, Abdulrahman (AIT) Bott, Christoph (MLU), Akbar, Shariq (THI), and Müller, Simon (THI)	First draft
2	26/12/2024	1 <sup>st</sup> revision	Markku Hagström (GTK), Sami Vallin (GTK), Kati Ahlqvist (GTK), Kimmo Korhonen (GTK), Teppo Arola (GTK)	First revision
3	27/12/2024	Coordinator revision	Peter Bayer (MLU)	Final formal checks
4	31/12/2024	Submission	Peter Bayer (MLU)	Upload

## INTERSTORES Consortium

No.	Partner organisation name	Short name	Country	Role*
1	MARTIN-LUTHER-UNIVERSITAT HALLE WITTENBERG	MLU	DE	COO
2	AIT AUSTRIAN INSTITUTE OF TECHNOLOGY GMBH	AIT	AT	BEN
3	STICHTING GLOBAL ENERGIESPRONG ALLIANCE	GEA	NL	BEN
4	GREENFLEX	GFX	FR	BEN
5	GEOLOGIAN TUTKIMUSKESKUS	GTK	FI	BEN
6	IN-CAMPUS GMBH	INC	DE	BEN
7	INOSENS DOO NOVI SAD	INO	RS	BEN
8	PLANUNGSGRUPPE M + M AKTIENGESELLSCHAFT LNGENIEURGESELLSCHAFT FUR GEBAUDETECHNIK	PGM	DE	BEN
9	TECHNISCHE HOCHSCHULE INGOLSTADT	THI	DE	BEN
10	VANTAAN ENERGIA OY	VNT	FI	BEN
11	TEKNOLOGIAN TUTKIMUSKESKUS VTT OY	VTT	FI	BEN
12	WIZ DEVELOPMENT & SERVICES SRL	WIZ	RO	BEN
13	FACHHOCHSCHULE ZENTRALSCHWEIZ HOCHSCHULE LUZERN	HLU	CH	AP
14	CHALLOCH ENERGY LTD	CEN	UK	AP

\**Role*: COO-Coordinator; BEN-Beneficiary; AE-Affiliated Entity; AP-Associated Partner

## QUALITY OF INFORMATION - DISCLAIMER

Funded by the European Union. Views and opinions expressed are however those of the author(s) only and do not necessarily reflect those of the European Union or the European Climate, Infrastructure and Environment Executive Agency (CINEA). Neither the European Union nor the granting authority can be held responsible for them.

### Copyrights

This document contains unpublished original work unless clearly stated otherwise. Previously published material and the work of others have been acknowledged by appropriate citation, quotation, or both.

© INTERSTORES Consortium, 2024

Reproduction is authorised provided the source is acknowledged.

EU Approval Pending

## Table of Contents

TABLE OF CONTENTS .....	5
LIST OF FIGURES .....	7
LIST OF TABLES .....	7
1 INTRODUCTION .....	9
2 CONCEPTS FOR STES STORAGE MEDIUM .....	11
2.1 RELEVANT MATERIAL PROPERTIES .....	11
2.2 CONVENTIONAL MATERIALS .....	12
2.2.1 Water .....	12
2.2.2 Two-phase fillings/water-gravel mixtures .....	13
2.2.3 INTERSTORES' advancements for conventional filling materials .....	14
2.3 INNOVATIONS FOR SEASONAL THERMAL ENERGY STORAGE FILLINGS .....	15
2.3.1 Extension by avoidance of thermal insulation .....	15
2.3.2 Re-use of volumes .....	15
2.3.3 Re-use of materials .....	16
2.3.4 Integration of latent storage materials .....	16
2.3.5 Integration of supporting structures for water-based technology types .....	17
2.3.6 Use of pressurised water .....	17
3 CONCEPTS FOR STES CHARGING AND DISCHARGING DEVICES .....	18
3.1 TYPES OF CHARGING DEVICES FOR STES .....	19
3.1.1 Direct charging .....	19
3.1.2 Indirect charging .....	19
3.1.3 Hybrid charging .....	21
3.2 TYPES OF DISCHARGING DEVICES FOR STES .....	22
3.2.1 Direct discharge .....	22
3.2.2 Indirect discharge .....	22
3.2.3 Cascaded discharge .....	22
3.3 DESIGN CONSIDERATIONS FOR CHARGING AND DISCHARGING DEVICES .....	23
3.3.1 Material selection and compatibility .....	23
3.3.2 Spatial configuration .....	23
3.3.3 Maintenance and accessibility .....	23
3.4 INNOVATIONS IN CHARGING AND DISCHARGING TECHNOLOGIES .....	24
3.4.1 Advanced heat exchanger designs .....	24
3.4.2 TCMs and PCMs integration .....	24
3.4.3 Combination of direct and indirect charging and discharging .....	24
3.4.4 Design of indirect charging and discharging .....	25
4 CONCEPTS FOR STES INSULATION .....	27
4.1 ENVELOPE OF BURIED STES .....	27
4.2 INSULATION DISTRIBUTION IN STES ENVELOPE .....	28
4.2.1 Top cover insulation .....	30
4.2.2 Sidewall insulation .....	30
4.2.3 Bottom insulation .....	30
4.2.4 Multi-layered insulation approach .....	30
4.3 INSTALLATION TECHNIQUES OF INSULATION FOR STES APPLICATIONS .....	30
4.4 INSULATION MATERIALS FOR STES APPLICATIONS .....	31
4.4.1 Conventional insulation materials .....	31
4.4.2 Natural insulation materials .....	32
4.4.3 Recycled insulation materials .....	33
5 CONCEPTS FOR OPTIMAL OPERATION – CHARGING MANAGER .....	34

5.1	KEY TASKS OF THE CHARGING MANAGER .....	35
5.1.1	Balancing the load.....	35
5.1.2	Maintaining thermal stratification.....	35
5.1.3	Utilising energy sources.....	35
5.2	CONTROL APPROACHES FOR CHARGING MANAGER.....	36
5.2.1	Rule-based control.....	36
5.2.2	Model predictive control.....	36
5.2.3	Model-free approach.....	37
5.3	KEY PERFORMANCE INDICATORS.....	37
5.3.1	Thermal losses.....	37
5.3.2	Energy efficiency.....	37
5.3.3	Storage capacity.....	37
5.3.4	Response time.....	38
5.3.5	System flexibility.....	38
5.4	COMPONENTS AND TOOLS.....	38
6	SUMMARY AND OUTLOOK.....	39
7	REFERENCES.....	40

EU Approval Pending

## List of Figures

Figure 1: Primary dimensions and their secondary products influencing the planning and construction of large-scale underground TES and its economic feasibility (reproduced from [6]).	10
Figure 2: Key material parameters of sTES filling materials.	12
Figure 3: Advantages and disadvantages of water as sTES filling material.	13
Figure 4: Advantages and disadvantages of water-gravel mixtures as sTES filling material.	14
Figure 5: Conceptual approach of an extended filling volume within the subsurface around an sTES facility (left), and a resulting thermal plume in a test simulation with groundwater flow (right). (reproduced from [20]).	15
Figure 6: Conceptual illustration of the proposed integration of latent storage materials in the edge regions of sTES fillings.	16
Figure 7: Different levels of stratification for the same amount of stored heat (a) highly stratified, (b) moderately stratified, and (c) fully mixed storage. (1) Hot region, (2) thermocline, (3) cold region, and (4) uniform temperature (reproduced from [1]).	18
Figure 8: Direct charging mechanism with liquid storage medium in sTES (reproduced from [2]).	19
Figure 9: Schematic of equal- and nonequal-diameter radial diffusors.	19
Figure 10: Indirect charging mechanism with solid storage medium (gravel) in sTES (reproduced from [2]).	20
Figure 11: Examples of indirect charging mechanisms (reproduced from [30]).	21
Figure 12: An exemplary hybrid charging combining mantle heat exchanger for indirect method with diffusors for direct charging.	21
Figure 13: Indirect discharge through an embedded heat exchanger within water-gravel PTES.	22
Figure 14: Example of a tank with a built-in stratified for charging and discharging.	23
Figure 15: An exemplary concept for combined direct and indirect charging and discharging mechanisms.	24
Figure 16: Tichelmann concept for indirect heat transfer showcasing charging conditions.	25
Figure 17: A proposed novel layout for indirect charging and discharging of sTES.	26
Figure 18: A novel layout for indirect heat transfer in sTES applications.	27
Figure 19: Layout of a composite side wall for a water-gravel sTES, insulation inside with respect to the concrete/steel structure (reproduced from [1]).	28
Figure 20: Layout of a composite side wall for a water-gravel sTES, insulation outside with respect to the concrete/steel structure (reproduced from [1]).	28
Figure 21: Illustration of several insulation distribution configurations for sTES systems (reproduced from [36]).	29

## Abbreviations and Acronyms

ATES	Aquifer Thermal Energy Storage
CTES	Cavern Thermal Energy Storage
DH	District Heating
EC	European Commission
EPS	Expanded Polystyrene
FG	Foam Glass
HX	Heat Exchanger
KPI	Key Performance Indicator
MPC	Model Predictive Control
PCM	Phase Change Material
PE	Polyethylene
PTES	Pit Thermal Energy Storage
PU	Public
PUR	Polyurethane
R-DH	Renewables-powered District Heating
RES	Renewable Energy Source
SEN	Sensitive
SOC	State of Charge
sTES	Seasonal Thermal Energy Storage
T	Task
TTES	Tank Thermal Energy Storage
UTES	Underground Thermal Energy Storage
VIP	Vacuum Insulation Panel
WGTES	Water-Gravel Thermal Energy Storage
WGTES	Water-Gravel Thermal Energy Storage
WP	Work Package
XPS	Extruded Polystyrene

# 1 Introduction

Seasonal thermal energy storage<sup>1</sup> (sTES) is positioned to play a pivotal role in future district heating (DH) systems, especially as renewable energy sources (RESs) such as solar energy become increasingly integrated [1]. Given the seasonal requirements, these storage systems often require large volumes [2], which, when combined with RES-powered district heating (R-DH), provide substantial flexibility to balance energy supply and demand [1]. Further, it is important to mention that district heating (DH) systems can include also non-seasonal renewables (e.g., geothermal energy, and waste heat) [3].

sTES systems are mostly either buried in the ground (partially or fully) or built close to the surface and, therefore, those systems are frequently called Underground Thermal Energy Storage (UTES) systems. Out of the various types of sTES systems investigated in the literature, the most common ones in practice are: (1) Aquifer thermal energy storage (ATES) system, (2) Borehole thermal energy storage (BTES) system, (3) Tank thermal energy storage (TTES) system, (4) Pit thermal energy storage (PTES), and (5) Cavern thermal energy storage (CTES) system. The decision to employ a specific UTES concept depends strongly on the hydrogeological conditions of the respective location. Some technologies are well suited for low-temperature DH applications (e.g. ATES, BTES), whereas others found their place favourably in high-temperature applications (e.g. PTES, CTES, TTES). This deliverable focuses mainly on the latter. Other technologies (i.e. ATES, BTES) are not covered in the main body of this deliverable.

Despite their potential advantages, sTES technologies face several barriers to broader expansion. High investment costs, space requirements and complex planning requirements are among the primary challenges [4]. Figure 1 illustrates the interdependent factors involved in large-scale sTES planning and construction. Additionally, in some regions, regulatory frameworks may delay construction and commissioning - especially where strict hydrogeological standards are implemented. In Europe, for instance, spatial restrictions for buried sTES installations are sometimes necessary to protect groundwater temperatures [5], highlighting the need for robust insulation solutions to mitigate sTES-groundwater interactions.

<sup>1</sup> A seasonal thermal energy storage shall have a single cycle per year through which the storage experiences charging, storage, discharging and idle phases. The storage shall help to shift the available heat in some months into other months.

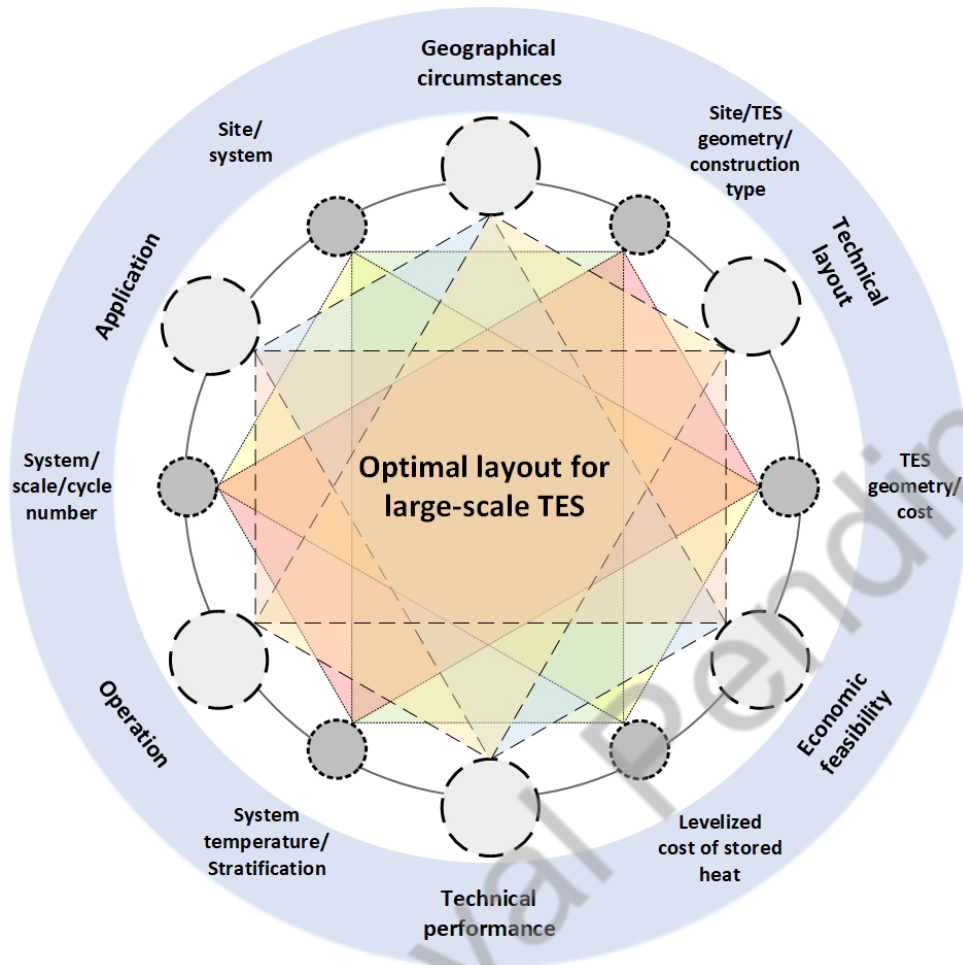

Figure 1: Primary dimensions and their secondary products influencing the planning and construction of large-scale underground TES and its economic feasibility (reproduced from [6]).

The majority of implemented sTES systems worldwide rely on sensible, water-based storage due to water’s high specific heat capacity (4.18 MJ/(m<sup>3</sup>·K) between 0°C and 95°C) [2], which results in high charging/discharging rates from a thermodynamic perspective. However, the use of water presents structural challenges for sTES construction, particularly for the cover. Maintaining a sealed, stable, and balanced envelope for water-based sTES requires advanced designs. Floating covers, typical of Denmark’s PTES installations, are one solution; however, these render the ground surface unusable, thus limiting the uptake of such sTES technologies in dense urban areas. By contrast, trafficable covers, while three times more costly, enable the use of sTES sites in high-density areas by reducing space demand.

An alternative sTES concept involves using solid storage media to enhance mechanical stability, potentially allowing for simpler, cost-effective cover designs and promoting broader market acceptance. For instance, water-gravel thermal energy storage (WGTES) systems use gravel as a storage medium, which reduces investment costs by simplifying structural requirements. Additional materials like crushed rock and sand are also viable; however, these require increased storage volumes to match the envisioned capacity of water-based systems.

Direct charging and discharging is possible with water-based sTES, enabling high energy charging/discharging rates, while systems using gravel or sand typically require indirect charging/discharging with heat exchangers. Thus, optimal planning of charging and

discharging processes is essential to ensure operational efficiency with acceptable response times. Furthermore, optimised control strategies during these cycles will improve overall system performance, reducing reliance on auxiliary heating or cooling sources. Thus, the use of thermal energy management schemes (e.g., charging manager) arises as a promising candidate for this area of application.

Within the framework of INTERSTORES, this deliverable aims to explore innovative sTES concepts and establish planning guidelines that drive down investment costs and accelerate market adoption.

## 2 Concepts for sTES storage medium

The storage medium of a thermal energy storage system is considered a key component. Accordingly, systems are classified based on the type of storage material (sensible, latent, or thermochemical) or their technological implementation, such as UTES or alternative designs. Latent heat storage, for example, leverages phase change materials (PCMs) like water/ice or hydrocarbons (e.g., paraffin wax), storing and releasing amounts of energy during melting and solidification [7]. Thermochemical storage is based on reversible chemical reactions, such as salt hydration, which achieve comparatively high energy densities [8]. While these concepts hold significant potential, their practical application in seasonal contexts is limited due to high material costs and technical complexities. Sensible heat storage, in contrast, remains the currently most widely adopted approach for large-scale applications [9]. This method relies on temperature changes within the storage filling. Thereby, sensible sTES often involves the application of large pits or tanks, with volumes reaching several thousand cubic meters, to store thermal energy over extended periods.

In recent years, a growing interest emerged in optimising filling materials for sTES to improve energy efficiency, reduce costs, and enhance scalability. This chapter introduces the conventional materials used as storage media, exploring their physical and thermal properties, environmental impact, and suitability for practical applications. By further introducing INTERSTORES' advancements in material use and storage design, the following chapter aims to highlight the critical role of filling materials and proposed innovations of the project for advancing sTES technologies.

### 2.1 Relevant material properties

The performance of sTES systems depends heavily on the filling materials' characteristics (Figure 2). They must meet various requirements to ensure the system operates efficiently, remains durable over time, and complies with sustainability goals. An evaluation of material properties should be guided by standardised procedures and established scientific practices. Optimal materials are assessed based on their technical performance, economic viability, and environmental impact, balancing these factors to meet the requirements of sTES systems.

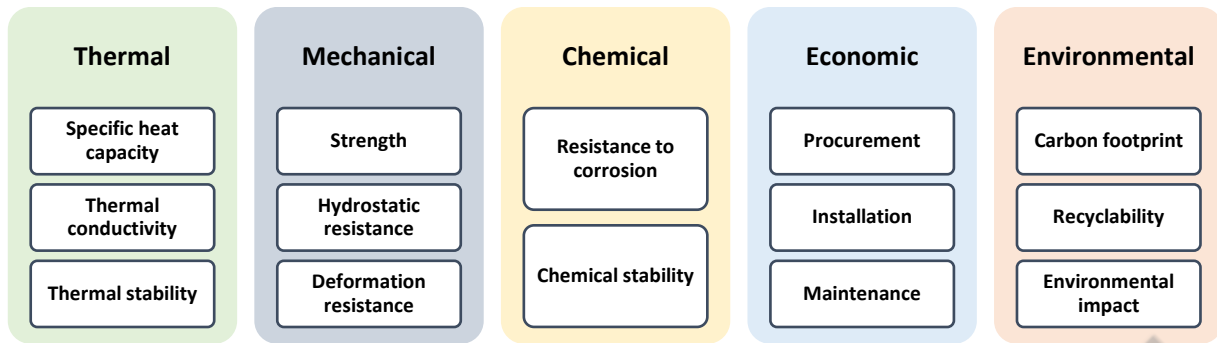

Figure 2: Key material parameters of sTES filling materials.

Thermal factors include the ability to store and transfer heat effectively [10]. High thermal capacity is essential to maximise storage potential, while efficient heat transfer minimises losses during charging and discharging cycles. Durability and stability are critical, as filling materials in sTES systems are exposed to extreme cyclic thermal conditions. Materials must tolerate different conditions, and indicators such as maximum, minimum, and average temperatures, along with temperature gradients, are used to evaluate their resilience and overall effectiveness. Economic considerations are crucial, as large-scale systems require cost-effective materials that are both abundant and inexpensive. Capital costs, often expressed as water-equivalent costs, are a key factor in determining the feasibility of a material for practical applications. Environmental compatibility means environmentally favourable, minimising their environmental footprint and potential local impacts [2]. This includes selecting non-toxic, recyclable materials that do not pose risks of environmental degradation. Mechanical properties, such as strength and resistance to deformation, are vital to withstand the physical stresses caused by external loads. For WGTES, permeability is further important. These characteristics influence water flow and heat exchange within the system, requiring a balance between effective heat transfer and material stability. Furthermore, resistance to chemical weathering, including corrosion and interactions with stored water, is essential for long-term performance.

## 2.2 Conventional materials

Geological UTES utilise natural subsoil and groundwater. In contrast, artificial seasonal thermal energy storage systems, such as tank thermal energy storage and water-gravel thermal energy storage basins, typically rely on readily available materials like water and gravel as storage media [2].

### 2.2.1 Water

Water is one of the most commonly used filling materials for sTES due to its economic, environmental, and thermodynamic advantages (Figure 3): It is readily available almost everywhere at a low cost, making it more affordable than high-quality gravel fillings [11]. Furthermore, water's dual role as both a storage medium and a heat transfer medium is beneficial. By using water directly as the working fluid, indirect heat exchangers can be avoided, simplifying system design and allowing seamless integration of the storage tank into heating or cooling networks. Thermodynamically, water performs well within the typical operating temperature range of sTES systems, with storage capacities reaching 60 to 80 kWh per cubic meter. This makes it highly efficient for retaining and transferring thermal energy over seasonal periods.

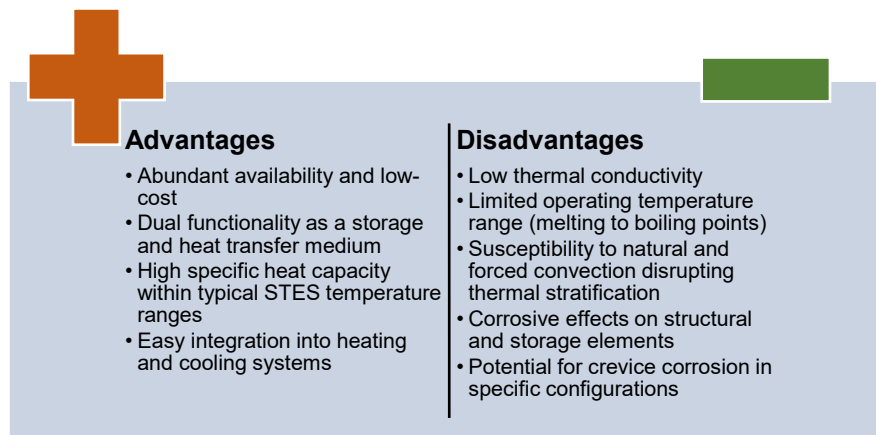

Figure 3: Advantages and disadvantages of water as sTES filling material.

Moreover, water has relatively low thermal conductivity (ca. 0.6 W/m K), which is lower than that of water-saturated soils (ca. 0.7 to 4 W/m K). This reduces the efficiency of conductive heat transfer. Another disadvantage is the limited temperature range of operation under unpressurised conditions, constrained by water's freezing and boiling points. Fluid dynamics can further complicate planning/modelling and operation: Natural convection can disrupt thermal stratification, mixing warmer and cooler layers, and reducing overall efficiency [12]. This issue is amplified by forced convection during charging or discharging cycles, which requires careful design of diffusor configurations and charging procedures. Finally, corrosive effects can pose a challenge, as water can cause significant corrosion to other storage elements, particularly metal components, through direct contact or humidity.

## 2.2.2 Two-phase fillings/water-gravel mixtures

Water-gravel thermal energy storage systems (WGTES) represent a class of STES systems that utilise a combination of water and solid materials, such as gravel, sand, or soil, as filling media [13]. These multi-component systems are versatile and may be further classified into earth-water and gravel-water storages, depending on the specific type of solid material used. Gravel-water systems are among the most common, offering unique thermal, structural, and practical advantages.

The thermal characteristics of water-gravel mixtures are influenced by the combined properties of the solid and liquid components. Thereby, well-sorted gravels increase storage capacity and enable more effective direct loading systems [2]. Gravel used in WGTES systems typically has a higher thermal conductivity than water alone, which enhances bulk heat transfer of the storage filling. For instance, in a WGTES system in Chemnitz, Germany [14] [15], coarse gravel with an average diameter of 22.3 mm (16-32 mm) and a porosity of 0.43 achieved a thermal conductivity of 2.4 W/m K (ca. four times higher than water). However, that mixture possesses a reduced thermal capacity of 2.98 MJ/m<sup>3</sup> K (water: 4.18 MJ/m<sup>3</sup> K). To compare the capacity of WGTES with pure water-based systems, the volume of the water-gravel mixture is converted into "water equivalents". This conversion accounts for the reduced water volume due to the presence of gravel while considering the heat capacity contribution of the solid material [16]. For example, the above-mentioned WGTES in Chemnitz thus has an equivalent storage volume of 5,300 m<sup>3</sup> (net WGTES volume: 8,000 m<sup>3</sup>).

One key benefit of water-gravel mixtures is their structural strength. The integration of the solid phase provides stability, allowing a load-bearing structure. This makes WGTES advantageous in densely populated areas where land use is a concern. For example, the cover of a WGTES in Steinfurt, Germany is used as a garden, a multifunctional urban space [17].

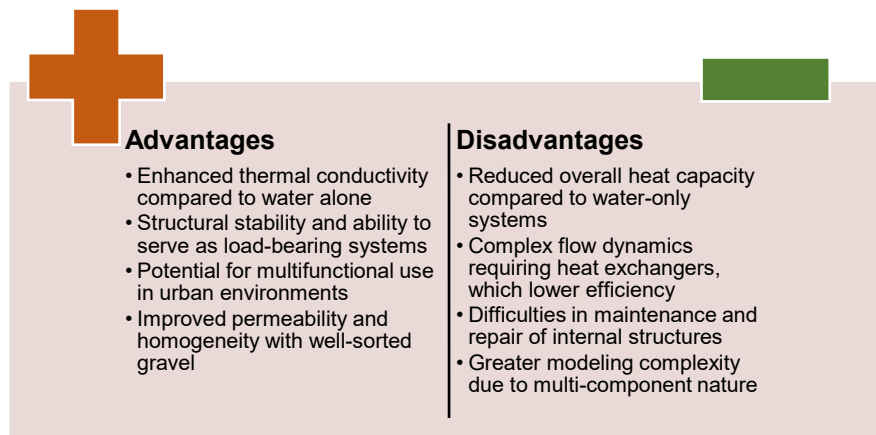

Figure 4: Advantages and disadvantages of water-gravel mixtures as sTES filling material.

Despite these advantages, the heterogeneity of the mixture and the solid content complicates the design and maintenance of the thermal storage system, and charging/discharging solutions for WGTES are more demanding, as flow paths within the storage medium are difficult to control. Indirect heat exchangers are required to prevent clogging and ensure effective heat transfer, yet improper layouts might introduce inefficiencies [8]. Maintenance challenges are another significant limitation, as repairs to the internal components are almost impossible after construction. Furthermore, the complexity in modelling WGTES systems is greater than that of water-only systems due to potential (e.g., chemical) interactions between liquid and solid components.

### 2.2.3 INTERSTORES' advancements for conventional filling materials

Efforts to enhance the performance of conventional filling materials for sTES are a critical focus of ongoing research. The expected advancements from these efforts include improved resistance, enhanced thermal and hydraulic performance, and more reliable modelling methodologies for conventional sTES filling materials. By addressing these challenges, INTERSTORES aims to refine the use of conventional filling materials, while also considering further innovative approaches, as introduced in the following section.

At the VECTES Giga-CTES demonstrator within the INTERSTORES project, significant attention is being directed toward mitigating crevice corrosion within the filling volume. Thereby, an accumulation of contaminants from the walls and the filling (i.e., water), can accelerate corrosion processes. In this respect, INTERSTORES aims to ensure the long-term reliability and structural stability of CTES systems. For that understanding and optimising the mechanisms of free and forced convection within the storage medium is relevant, and interactions between water and structural components are studied. The corresponding results may be used to further enhance the overall performance and reliability of other water-based sTES technology types.

For the Reno-sTES demonstrator within INTERSTORES [18], advancements focus on optimising a porous media filling. Laboratory investigations are examining bulk thermal properties and hydraulic characteristics. These activities aim to identify optimum compositions and configurations that enhance heat transfer and fluid flow within the filling material. Another innovation area is the refinement of modelling tools for WGTES: INTERSTORES develops advanced modelling tools [19], that account for sophisticated behaviours of WGTES filling materials. These tools aim to provide a more accurate representation of system behaviour, enabling better design, operation, and optimisation of WGTES systems.

## 2.3 Innovations for seasonal thermal energy storage fillings

### 2.3.1 Extension by avoidance of thermal insulation

INTERSTORES innovative approaches to artificial, ground-based sTES are exploring the potential of uninsulated storage designs. As the performance of sTES systems depends on operational temperatures and insulation levels, this strategy utilises natural thermal interactions between the storage facility and its surrounding environment, allowing the adjacent soil to become an active component (Figure 5, left) [20]. By avoiding traditional insulation techniques, which are a significant cost factor, this innovation is intended to expand storage capacity and optimise efficiency. While insulation minimises heat loss, it avoids beneficial exchanges with the environment. Instead, uninsulated designs allow thermal energy to dissipate into the surrounding ground, creating a dynamic thermal exchange with the soil as a natural buffer after the initial heating phase of a facility [21].

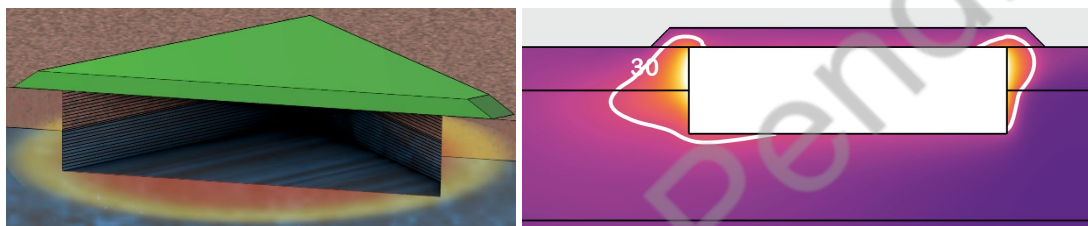

Figure 5: Conceptual approach of an extended filling volume within the subsurface around an sTES facility (left), and a resulting thermal plume in a test simulation with groundwater flow (right). (reproduced from [20])

Factors such as soil characteristics and hydrogeological conditions (Figure 5, right) influence the efficiency of this interaction [22] [19], and the advanced modelling tools developed in INTERSTORES are essential for evaluating these effects and optimising designs for ecological and economic benefits. Further, the Reno-STES demonstrator in Ingolstadt explores such uninsulated WGTES systems in practice. With a thermal capacity of around 380 MWh, interactions between the storage and the subsurface are envisaged based on a dispensation of insulation material. Research focuses on factors such as porosity, and thermal conductivity, and their effects on efficiency and thermal losses.

### 2.3.2 Re-use of volumes

The reuse of existing volumes sTES emphasises sustainability by repurposing ground-based structures [23]. This may reduce environmental impacts and enhance economic feasibility, making the sTES technology more market mature. Disused pits, such as a PTES in Denmark [24], or decommissioned caverns are examples of volumes that can be converted into sTES facilities. This strategy addresses significant economic barriers, as reusing infrastructure eliminates the high costs of new construction [25]. Further, it employs circular economy principles, reducing the demand for new materials, lowering carbon footprints, and extending the lifecycle of existing structures. However, structural assessments and adaptations may be required to ensure tightness, thermal efficiency, and integration into existing energy systems.

INTERSTORES' Reno-sTES demonstrator showcases a practical application of this approach, where existing ground-based structures are converted into a WGTES system [18]. Thus, INTERSTORES explores the economic and environmental advantages of repurposing volumes, proving that reusing existing structures for sTES represents an opportunity to implement adaptable energy storage systems in current transformation settings.

### 2.3.3 Re-use of materials

Reusing materials for sTES can reduce costs and environmental impact by employing excavated materials as sTES fillings [13]. This approach can minimise material disposal and procurement costs while improving resource efficiency. To date, WGTES have often faced economic barriers due to excessive material costs for high-quality gravel fillings. By repurposing excavated materials, these challenges can be mitigated: As an example, in Eggenstein, Germany, locally available well-permeable sand was already used as the storage filling, reducing costs and avoiding off-site material transport [26].

INTERSTORES promotes material recycling in different respects, to develop sustainable solutions with minimal primary resource consumption. At the Reno-STES demonstrator in the IN-Campus, refurbished gravel from the site is reused as the filling material, and existing plastic membranes are used to seal the sTES, showcasing an integrated reuse approach [18]. Similarly, the excavation works of the VECTES Giga-TES demonstrator yield crushed rock material – a potential filling material for other WGTES facilities. Hydrogeological and thermal characterisations within INTERSTORES will reveal if these materials meet the required performance characteristics. Besides, reusing these materials will prove economic savings, the reduction of carbon emissions, and the practical feasibility. The Reno-STES and VECTES Giga-TES demonstrators highlight the feasibility of material recycling, providing valuable insights for future sTES designs.

### 2.3.4 Integration of latent storage materials

The integration of phase change materials (PCMs) into the edge regions of sTES filling materials (Figure 6, left) presents another novel approach to improving storage capacity and system efficiency [27]. While traditionally excluded from large-scale sTES systems due to high costs, PCMs can be selectively applied in edge zones, leveraging benefits without employing them as the entire storage filling.

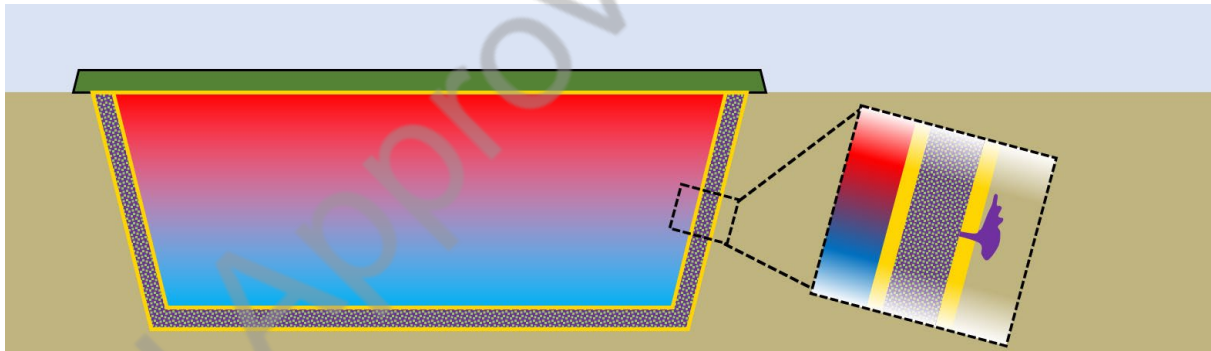

Figure 6: Conceptual illustration of the proposed integration of latent storage materials in the edge regions of sTES fillings.

Although this concept is not explicitly covered by the INTERSTORES project, the use of PCMs in sTES can offer distinct advantages, including enhanced thermal capacity, delayed heat transfer to the surroundings, and reduced material stress due to their ability to buffer rapid thermal changes. Based on their ability to store latent heat during melting and release it during solidification, they may serve to stabilise temperature fluctuations [7]. Moreover, liquid hydrophobic PCMs may act as self-healing agents, sealing cracks or voids in insulation membranes [28], by solidifying upon cooling. The self-sealing property (Figure 6, right) adds operational reliability, reducing water loss and maintenance costs. However, the high material cost of PCMs remains a challenge, particularly for large-scale adoption. Despite these limitations, PCM-enhanced sTES systems represent a promising direction for sustainable and efficient thermal energy storage.

### 2.3.5 Integration of supporting structures for water-based technology types

Another innovative approach for sTES fillings involves incorporating supporting structures, such as boxes or modular infiltration systems, into water-based storage facilities. This can combine the high heat storage capacity of water with the structural benefits of solid fillings [2], creating a hybrid system that retains thermal efficiency while improving mechanical stability. Supporting structures enable efficient water distribution and circulation, heat transfer and thermal stratification. Unlike gravel, they have a higher porosity, allowing for more water volume. Besides, their durability, recyclability and ability to be maintained during operation make them a sustainable option. The approach reduces the environmental and economic costs of materials like gravel and simplifies maintenance due to the modularity of the framework [29].

However, integrating such supportive structures introduces challenges, such as increased construction complexity and costs. Besides, they must be compatible with heat exchange systems, and the requirement of long-term stability would require rigorous testing and validation. Although this concept is not explicitly part of INTERSTORES research and innovation activities, it was considered an alternative for the Reno-sTES and remains a promising, recommended path for future research.

### 2.3.6 Use of pressurised water

Pressurised water emerges as a practical medium for sTES applications due to its ability to retain significant thermal energy at elevated temperatures and its compatibility with existing DH systems (e.g. primary networks). By maintaining water under pressure, it can be heated above its standard boiling point of 100°C, reaching temperatures up to 150°C or higher. This capability makes pressurised water ideal for applications requiring high-temperature thermal energy (e.g. industrial processes and DH).

The use of pressurised water offers several advantages, including high energy density, cost-effectiveness, and adaptability. Its abundance and non-toxic nature further enhance its sustainability. Unlike alternative storage media (e.g. PCMs or thermochemical materials (TCMs)), pressurised water resists degradation, ensuring long-term reliability. Many industrial processes (e.g. chemical production and food processing) require temperatures above 100°C. Pressurised water sTES enables direct integration of DH networks with these processes, reducing reliance on on-site boilers or additional heating equipment.

However, certain challenges must be addressed for wider uptake. The sTES envelope and piping must withstand high pressures and temperatures (e.g. temperature-induced stresses), requiring advanced materials like stainless steel or composites, which can significantly increase specific costs. Research and development into cost-effective, durable materials is critical to lowering the upfront costs of pressurised water systems. Additionally, high temperatures (e.g., > 130°C) can present significant challenges, particularly due to chemical reactions that may occur between the hot water and the storage envelope materials. These limitations are being actively addressed through the INTERSTORES project and the VECTES Giga-CTES demo-site, which aim to develop innovative materials and designs for pressurised sTES applications.

### 3 Concepts for sTES charging and discharging devices

Charging and discharging mechanisms and associated components play a critical role in sTES systems to efficiently harness and release thermal energy (i.e. heat and cold) effectively. These processes directly impact the energy system performance, responsiveness, temperature levels and overall energy efficiency. Properly planned and designed charging and discharging devices ensure optimal temperature stratification within the sTES system (in case of sensible TES application), maintaining the thermal layers necessary for energy-efficient operation and separating the hot region from the cold region via a thermocline. In this regard, Figure 1 illustrates the thermocline region and the different degrees of stratification within a storage tank for the same amount of stored heat. In case (a): the thermocline region is small compared to the second case (b). This results in a large temperature gradient ( $\partial T/\partial z$ ) between the hot and cold regions as shown in Figure 4(a). Whereas in case (b): the temperature gradient between the two regions is relatively smaller than that in case (a) (i.e.  $(\partial T/\partial z)_a > (\partial T/\partial z)_b$ ) due to enlargement in the thermocline region, as depicted by Figure 4(b). Accordingly, the storage in case (b) is considered less stratified than case (a). Compared to the previous cases, the storage in case (c) is at one uniform temperature and, therefore, the thermocline region completely disappears resulting in fully mixed storage (unstratified storage).

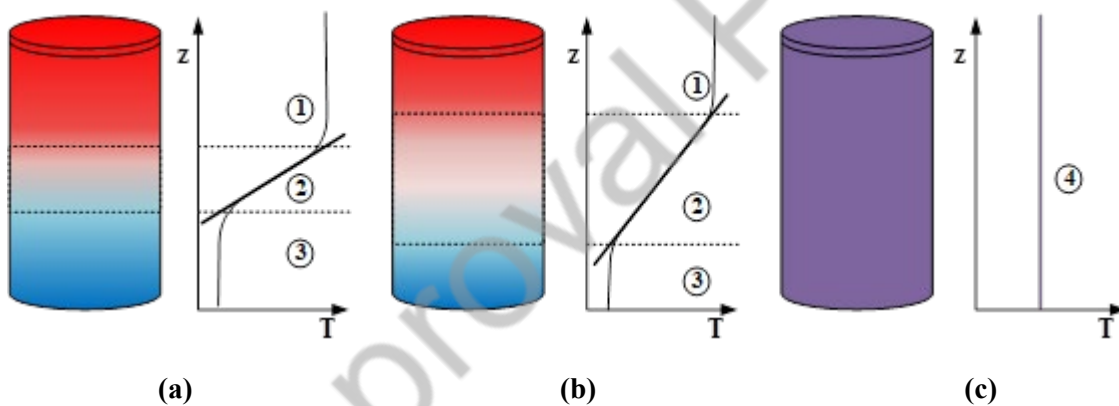

Figure 7: Different levels of stratification for the same amount of stored heat (a) highly stratified, (b) moderately stratified, and (c) fully mixed storage. (1) Hot region, (2) thermocline, (3) cold region, and (4) uniform temperature (reproduced from [1]).

A key player for good thermal stratification in sTES is the water inlet and outlet ports (e.g. design location). The design (e.g. geometry) of the charging and discharging devices has an impact on the stratification and, thus, an influence on the energetic efficiency of sTES. In addition, the design and operation of these devices are influenced by factors such as the storage medium, the scale of the system, and specific application requirements. By aligning charging and discharging mechanisms with the unique characteristics of the storage system, sTES can better accommodate fluctuating thermal energy supply from RES and meet seasonal energy demands.

## 3.1 Types of charging devices for sTES

### 3.1.1 Direct charging

The direct charging mechanism involves the transfer of thermal energy directly from the source to the storage medium, a technique suitable for sTES systems operating with liquid media such as water. This method maximises thermal efficiency by eliminating intermediary steps, allowing faster thermal energy recovery during the discharging process and minimising energy losses. Direct charging is commonly used in water-based sTES, where thermal energy from sources such as solar thermal collectors or industrial waste heat can be directly injected into the storage. However, in systems with solid media or non-compatible fluids, indirect charging methods are often preferred. Figure 8 shows two typical types of sTES (i.e. PTES and TTES) in which the charging devices are embedded within the body of sTES enabling direct exchange of thermal energy and energy carrier (e.g. water). Such devices can be radial diffusors as shown in Figure 9 whereby two configurations are illustrated. Otherwise, slotted pipe or H-beam diffusors can also be used.

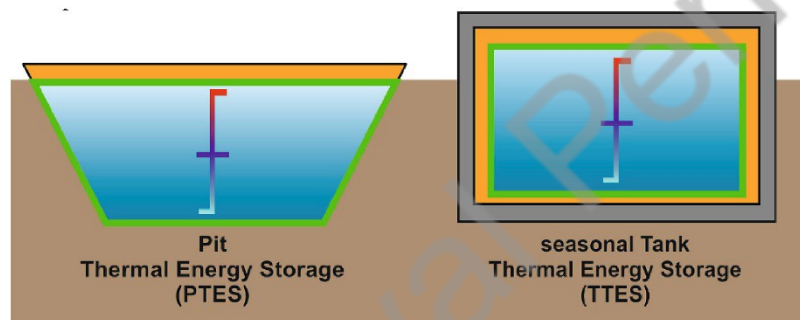

Figure 8: Direct charging mechanism with liquid storage medium in sTES (reproduced from [2]).

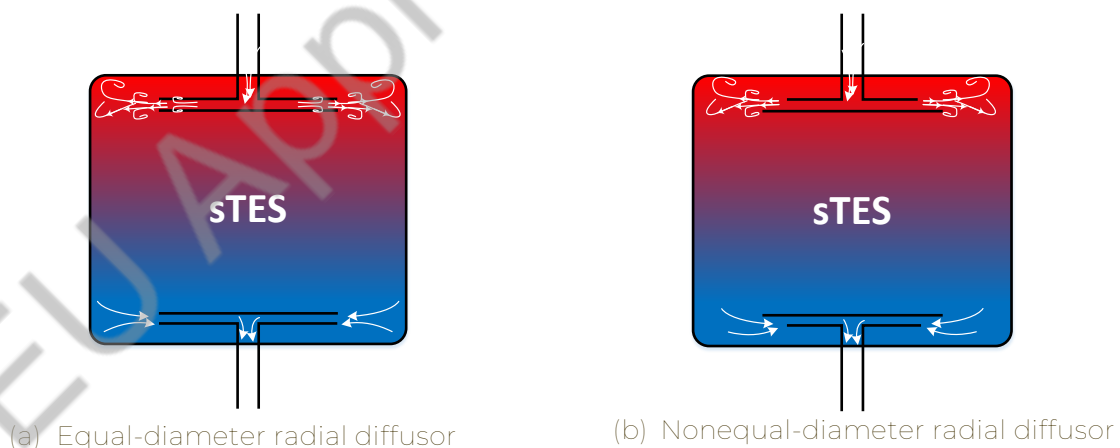

Figure 9: Schematic of equal- and nonequal-diameter radial diffusors.

### 3.1.2 Indirect charging

In indirect charging, individual heat exchangers are introduced within the sTES to facilitate the transfer of thermal energy from the source to the storage medium (accommodating diverse media such as gravel or sand). This method is advantageous in systems where direct

integration of the thermal energy source and storage medium may be impractical due to different media. Immersed or external heat exchangers are used to provide flexibility in system design. Figure 10 shows a typical water-gravel pit TES with an immersed heat exchanger for thermal energy charging. Such heat exchangers can have several configurations and geometries. For instance, Figure 11 exemplifies two typical indirect charging methods for sTES application. One is the use of immersed heat exchangers in different shapes (e.g. coil, racked, stairs or serpentine) as illustrated in Figure 11(a), the other can be the use of mantle heat exchangers embedded in sTES envelope as shown in Figure 11(b). Despite some efficiency losses compared to direct systems, indirect charging offers versatility, particularly in large-scale systems with complex configurations.

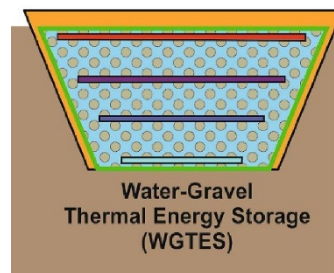
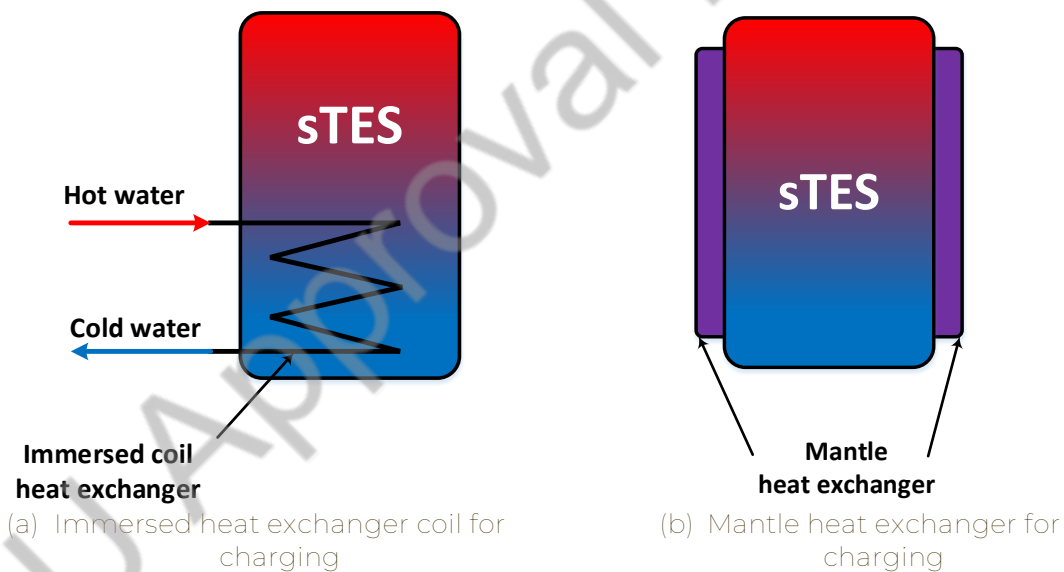

Figure 10: Indirect charging mechanism with solid storage medium (gravel) in sTES (reproduced from [2]).



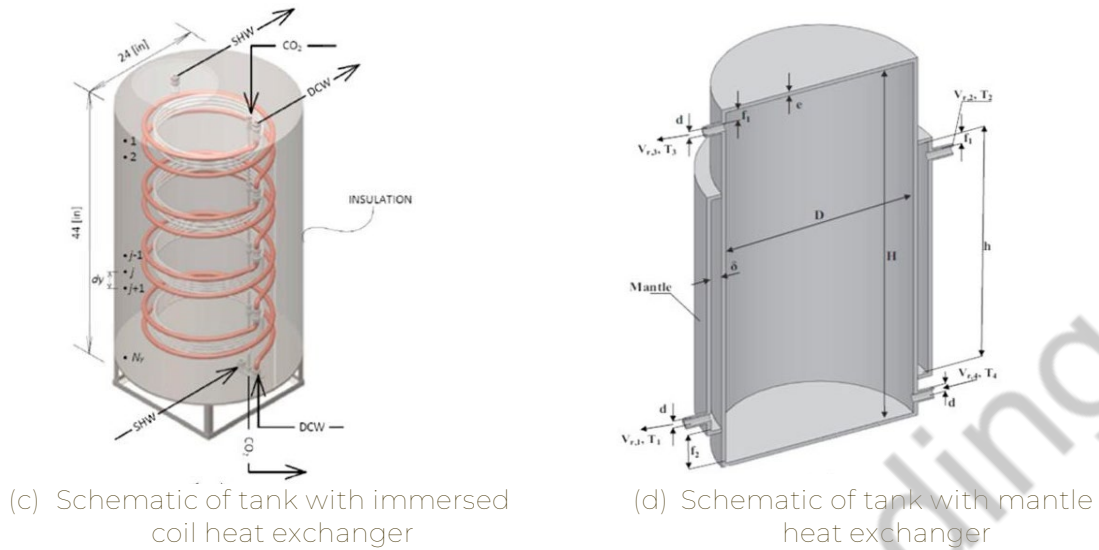

Figure 11: Examples of indirect charging mechanisms (reproduced from [30]).

### 3.1.3 Hybrid charging

Hybrid charging combines both direct and indirect charging methods to enhance system flexibility and efficiency. These systems can adjust dynamically to changes in thermal energy source availability and storage demands. Hybrid configurations are especially useful in multi-source sTES systems, where RES input may vary seasonally.

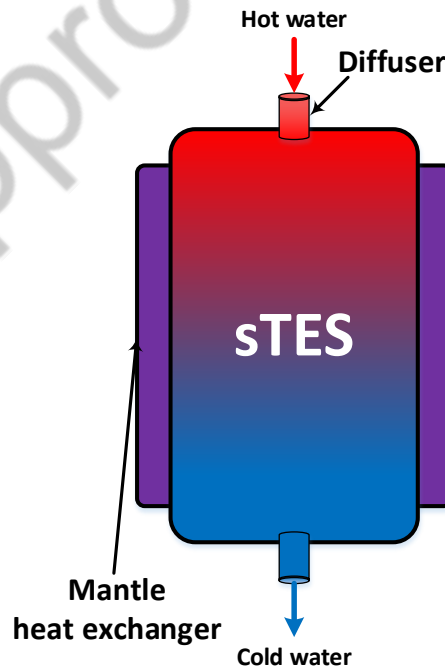

Figure 12: An exemplary hybrid charging combining mantle heat exchanger for indirect method with diffusers for direct charging.

## 3.2 Types of discharging devices for sTES

### 3.2.1 Direct discharge

Direct discharge systems involve the straightforward recovery of thermal energy from the sTES via the extraction of the storage medium, which makes it ideal for liquid-based media systems such as water-based sTES. This method provides quick access to stored thermal energy, making it ideal for applications with a high, prompt and instantaneous demand for thermal energy. Direct discharge is particularly effective in maintaining thermal efficiency as it avoids intermediary heat transfer losses reducing the temperature quality (i.e. exergy). This configuration is similar to the direct charging. Therefore, the devices can be used either for charging or discharging depending on the process in operation, whether charging or discharging.

### 3.2.2 Indirect discharge

When working with solid storage media or layered storage media setups (e.g. massive rock), indirect discharge via heat exchangers becomes essential. Immersed coil or racked heat exchangers within or adjacent to the storage medium allow thermal energy to be recovered effectively while preserving the structure of the storage system. Figure 13 schematically shows a water-gravel sTES using embedded heat exchangers for thermal energy extraction, emphasising the thermal energy path through the exchanger.

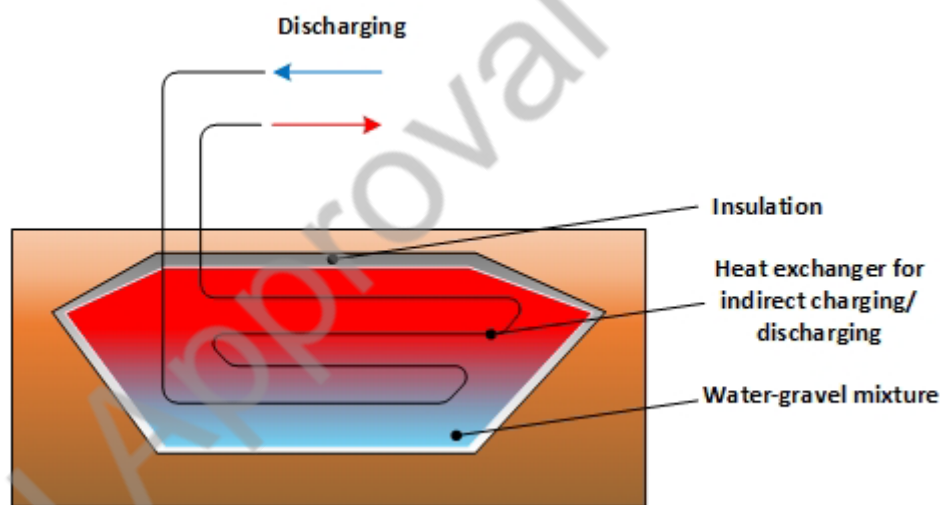

Figure 13: Indirect discharge through an embedded heat exchanger within water-gravel PTES.

### 3.2.3 Cascaded discharge

Cascaded discharge systems sequentially withdraw thermal energy from different thermal layers or zones, optimising thermal energy extraction and supporting system stratification. By tapping into various thermal layers, cascading minimises thermal mixing, helping maintain a higher temperature in the upper layers and improving overall storage efficiency. This method is especially advantageous in large sTES systems that store energy for extended seasonal use. Figure 14 shows a typical cascading discharging system known as “stratifier” within a tank storage.

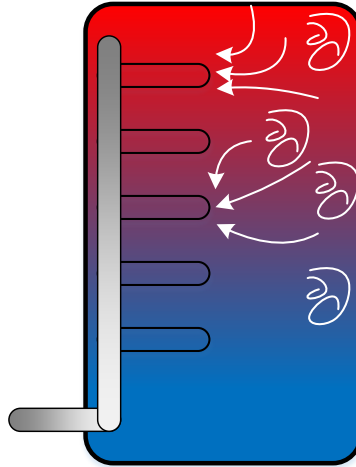

Figure 14: Example of a tank with a built-in stratified for charging and discharging.

### 3.3 Design considerations for charging and discharging devices

#### 3.3.1 Material selection and compatibility

Materials chosen for charging and discharging devices must withstand thermal cycling, pressure, and potential chemical interactions with the storage medium. Metals with high thermal conductivity, such as copper and stainless steel, are often preferred for heat exchangers due to their durability and efficiency. Proper material selection is crucial to avoid corrosion, wear, and potential thermal bridging, which can reduce efficiency. A recent trend is the use of polymeric heat exchangers for indirect charging and discharging [31]. This can lead to a decrease in the investment cost of sTES systems; however, it is crucial to examine the durability of the polymeric material under thermal cycling with temperature < 90°C.

#### 3.3.2 Spatial configuration

The optimal layout of charging and discharging devices within the storage medium is essential for even thermal energy distribution and minimal thermal bridging. Configurations such as centrally located exchangers for cylindrical tanks (i.e. TES) or layered heat exchangers for solid-media pits help maintain uniform thermal energy distribution. Proper spatial planning also reduces the risk of thermal hotspots, which can lead to material degradation and punctual energy loss.

#### 3.3.3 Maintenance and accessibility

Long-term durability and ease of maintenance are critical aspects of sTES applications – especially in larger systems. Planning of charging and discharging devices with accessibility for inspection, cleaning or replacement ensures sustained performance. Despite their superior performance, the use of direct charging/discharging devices might lead to a full operation stop for sTES applications in case of vandalism or damage that requires maintenance. The use of indirect heat exchangers might reduce such a risk as the damaged heat exchanger or transfer loop can be taken out of operation, whereas the rest is still in operation. Therefore, components that are easily accessible lower maintenance costs and improve the lifespan of the overall system.

## 3.4 Innovations in charging and discharging technologies

### 3.4.1 Advanced heat exchanger designs

Innovations in heat exchanger materials, shapes, and configurations aim to enhance thermal performance and system durability. New designs, including micro-channel and high-surface-area exchangers, increase heat transfer rates and reduce energy losses while also reducing the physical footprint of the device [31]. However, the micro-channels shape might trigger pressure losses to drastically increase leading to high pumping costs. The applications of such design can find its place favourably in indirect charging/discharging.

### 3.4.2 TCMs and PCMs integration

The integration of thermochemical storage materials or phase change materials can stabilise and enhance charging/discharging cycles. PCMs, in particular, can regulate temperature levels, helping to maintain an ideal thermal gradient [32]. These materials absorb and release heat at specific temperatures [33], improving energy density and allowing for more compact sTES solutions.

### 3.4.3 Combination of direct and indirect charging and discharging

This configuration incorporates both direct and indirect heat transfer methods for sTES applications using solid storage media (e.g. sand, gravel, or crushed rock). The combination of these two methods enhances system flexibility and overall efficiency, allowing the storage to adapt to varying operational demands. Figure 15 exemplifies a conceptual sTES system employing two individual charging and discharging mechanisms: one direct and the other indirect. Therein, heat exchangers facilitate the indirect transfer of thermal energy during charging and discharging, while wells are employed to circulate a liquid medium (e.g. water) through different layers of the storage medium. This design reflects the approach used in aquifer thermal energy storage (ATES), leveraging forced convection to improve heat transfer efficiency within the solid media. By integrating these two mechanisms, the sTES system can achieve enhanced thermal performance and operational adaptability, making it suitable for a wide range of applications.

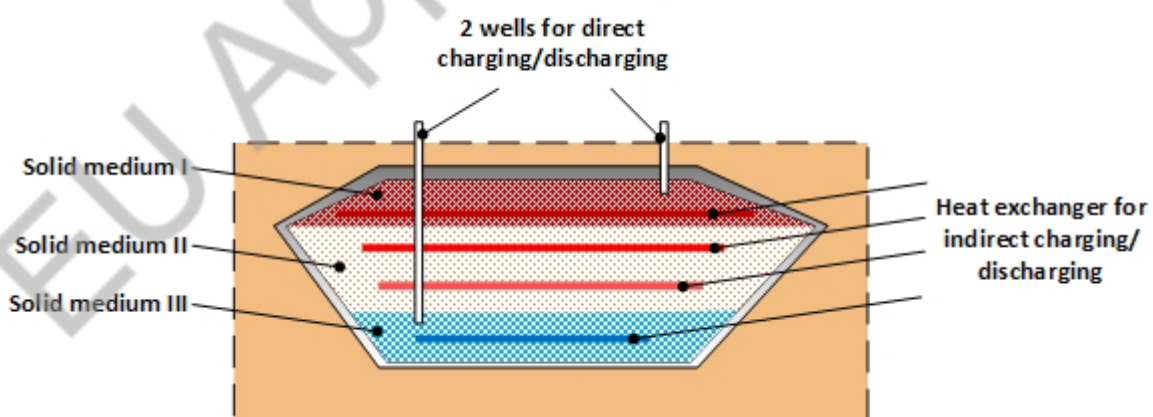

Figure 15: An exemplary concept for combined direct and indirect charging and discharging mechanisms.

### 3.4.4 Design of indirect charging and discharging

For indirect charging and discharging, the Tichelmann concept, also known as the reverse return flow configuration, is a well-established hydraulic design used in heating and cooling systems to achieve uniform fluid flow distribution across multiple parallel branches [34]. When applied to sTES systems, the Tichelmann concept provides an innovative approach to ensuring consistent heat transfer and efficient operation. Figure 16 illustrates the Tichelmann concept in action during the charging phase.

The Tichelmann layout is designed to balance flow resistance across all branches in the distribution network. In this configuration, the supply and return pipes are arranged so that the total length of the flow and return paths for each branch is equal. As a result, each branch experiences the same pressure drop, ensuring uniform fluid flow distribution. This uniformity minimises the risk of flow imbalances that could lead to uneven charging or discharging of thermal energy.

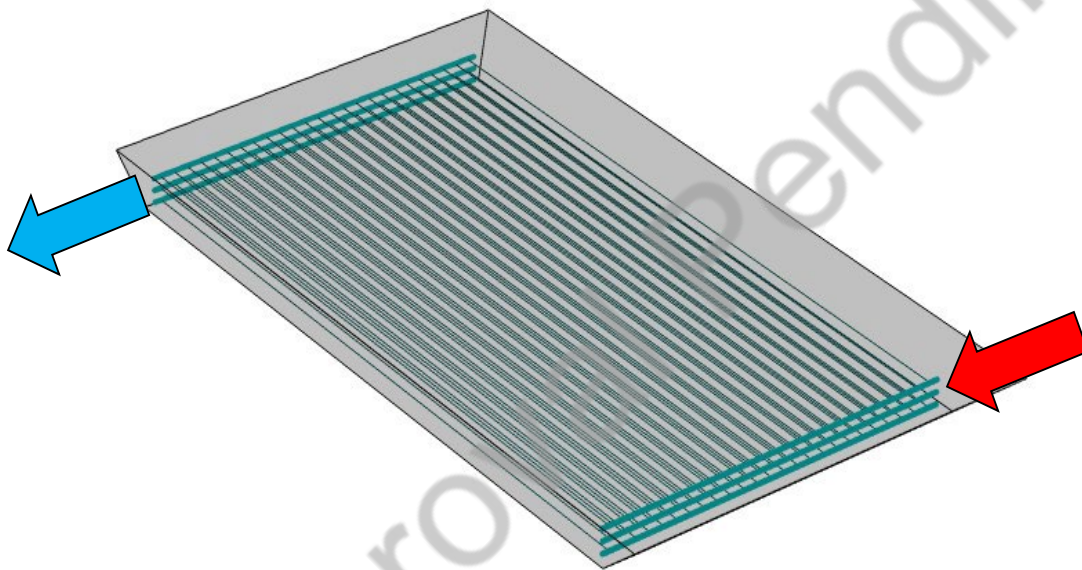

Figure 16: Tichelmann concept for indirect heat transfer showcasing charging conditions.

The Tichelmann configuration offers several advantages, including:

- **Uniform thermal energy distribution:** Ensures consistent thermal performance across the storage system.
- **Enhanced system stability:** Reduces the risk of localised overheating or stratification disturbances.
- **Lower pumping costs:** Optimised flow reduces energy requirements for pumping.

However, the Tichelmann concept also presents challenges, such as:

- **System complexity:** Precise pipe layout and balancing increase installation complexity.
- **Higher initial costs:** Additional piping and components add to upfront expenses.
- **Limited flexibility with variable flow rates:** Adapting to dynamic flow conditions can be challenging.

Another notable drawback is the system's vulnerability to interruptions caused by damage. If a single pipe is compromised, the entire system may need to halt charging or discharging temporarily. To address this limitation, an alternative configuration has been developed to

improve robustness and maintain partial functionality during damage. Figure 17 illustrates this novel concept.

In the proposed configuration, each heat transfer level consists of multiple independent loops. This design retains the balanced hydraulic benefits of the Tichelmann system while it has potential to enhance thermal performance. However, unlike the Tichelmann layout, the supply and return pipes are positioned closer to each other in this configuration, as shown in Figure 17, which may lead to increased heat dissipation and reduced heat transfer effectiveness. Despite this drawback, the key advantage of the novel layout is its resilience. If one loop is damaged, it can be isolated and taken out of operation, allowing the remaining loops within the same level to continue functioning without significant performance issues. This feature enhances the system's overall robustness, making it a promising alternative to the traditional Tichelmann configuration.

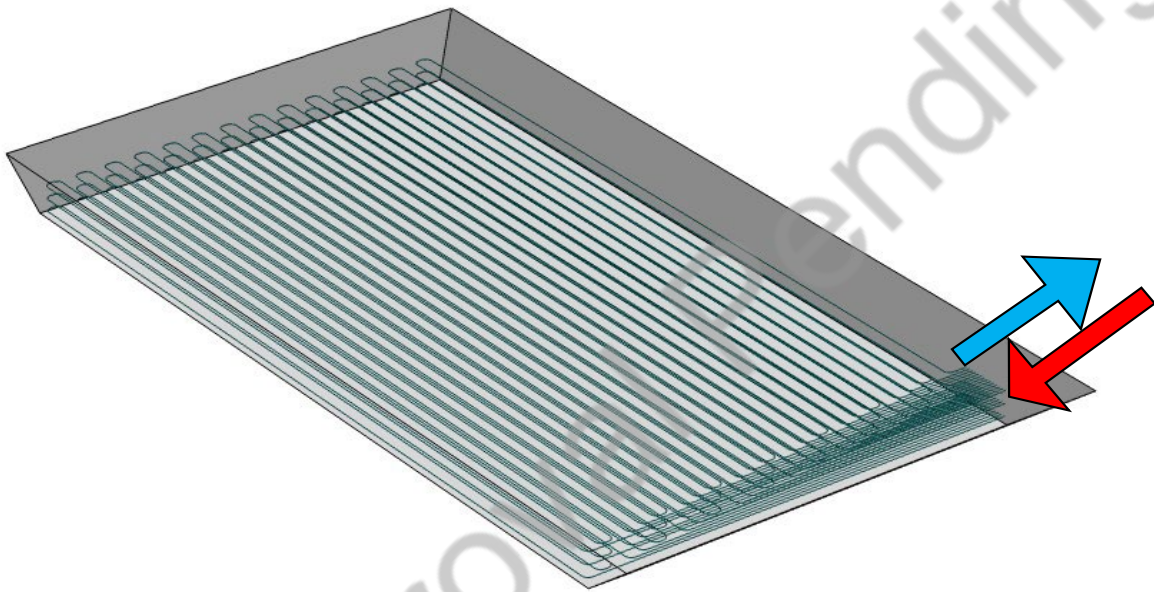

Figure 17: A proposed novel layout for indirect charging and discharging of sTES.

To address the primary drawback of the previous configuration, namely heat dissipation, an additional novel design is presented Figure 18. In this layout, the number of loops per heat exchange level is significantly reduced to four. The thermal energy is charged at the centre of the sTES, and the loops extend outward toward the side edges of the storage system. This configuration enhances the effectiveness of heat exchange between the storage medium and the thermal energy carrier by optimising the flow path and reducing thermal losses. Such a charging configuration allows for a concentration of thermal energy in the middle of sTES, whereas the thermal energy quality decreases towards the edges leading to less thermal losses.

While this design might improve heat transfer efficiency compared to Tichelmann concept, it may result in increased pressure losses due to the longer and more centralised flow paths. As such, it is essential to identify a trade-off that balances optimal charging and discharging performance with acceptable pressure losses, taking both technical and economic considerations into account. Careful evaluation of this trade-off is crucial to ensure the viability and efficiency of the system in practical applications.

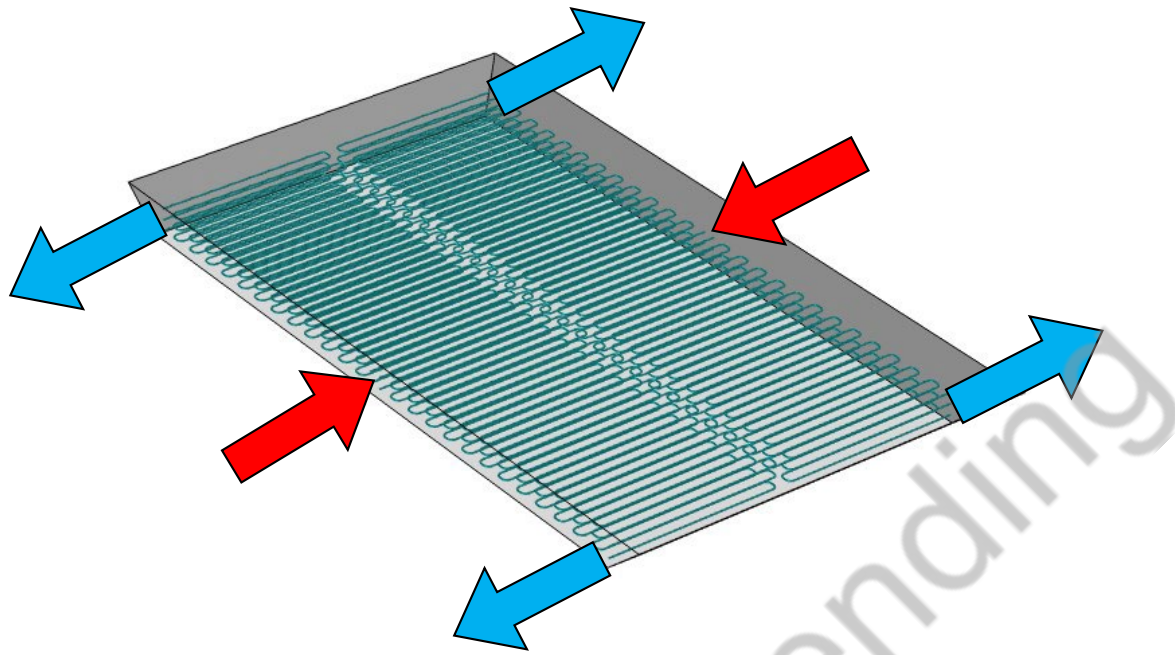

Figure 18: A novel layout for indirect heat transfer in sTES applications.

## 4 Concepts for sTES insulation

Effective insulation is a cornerstone of sTES systems, as it minimises thermal losses to the surroundings, enhances system efficiency and supports long-term thermal retention. They are also envisioned as a mitigation measure for the twofold impact of groundwater-sTES interaction resulting in acceptable groundwater quality. Insulation materials and their distribution within the sTES envelope directly impact performance, economic feasibility, and environmental footprint. This chapter firstly introduces the typical possibilities for realising sTES envelope and then explores insulation materials commonly used in sTES applications. It later examines strategies for the optimal distribution of insulation across different sTES designs.

### 4.1 Envelope of buried sTES

In buried sTES systems, external thermal losses often occur due to heat transfer between the sTES surface and surrounding ground, facilitated by the large interface area. Therefore, the minimisation of these thermal losses is crucial - especially when trading-off the insulation performance with economic considerations. Typically, large-scale sTES are enclosed by thick insulation layers, forming a composite wall as exemplified in Figure 19. Common insulation materials include polyurethane (PUR), glass wool, expanded polystyrene (EPS), extruded polystyrene (XPS) and foam glass (FG).

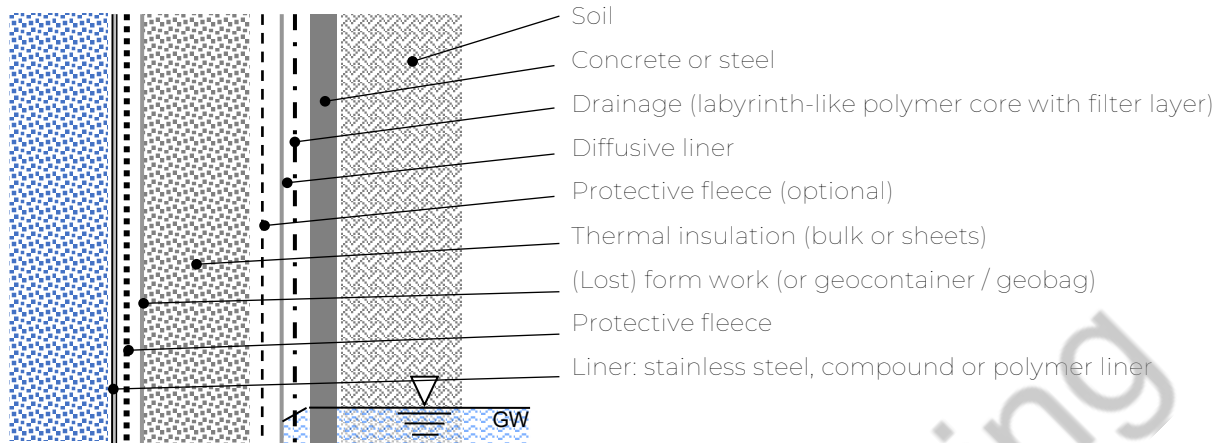

Figure 19: Layout of a composite side wall for a water-gravel sTES, insulation inside with respect to the concrete/steel structure (reproduced from [1]).

In a composite wall structure, insulation layers may be placed either inside or outside the primary construction material (usually concrete or steel). This approach impacts the thermal efficiency and durability of the system, as evident in the differences illustrated between Figure 19 and Figure 20. Insulation placement, whether internal or external, influences both the thermal performance and the overall stability of the sTES system, as well as construction and maintenance requirements.

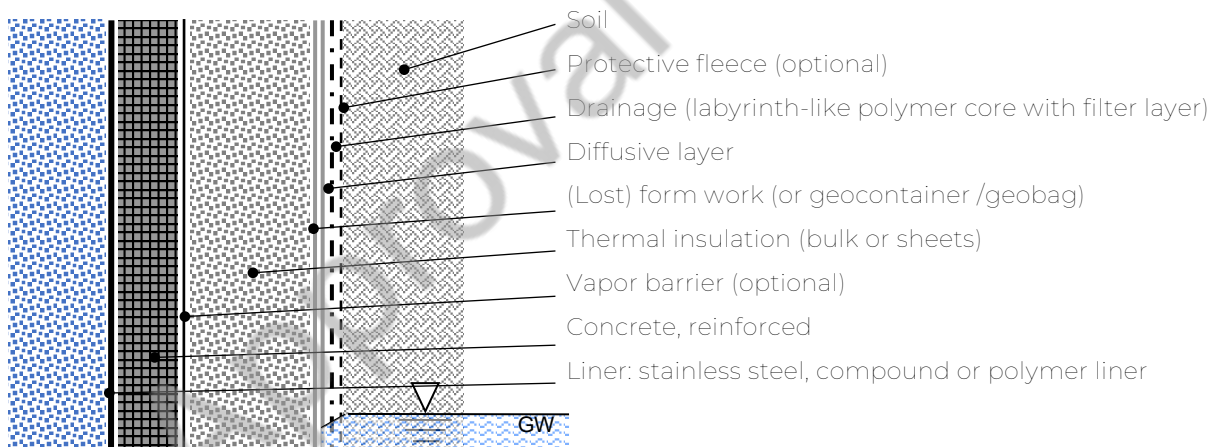

Figure 20: Layout of a composite side wall for a water-gravel sTES, insulation outside with respect to the concrete/steel structure (reproduced from [1]).

The sTES envelope must meet various requirements, many of which also apply to the insulation materials used. One of the most critical properties is high mechanical resistance, particularly at the bottom of the sTES system, where the substantial weight of the storage medium exerts significant pressure. Other essential material properties include uniform and continuous insulation application, durability, insensitivity to thermal stress and external environmental factors, as well as effective moisture management capabilities [1].

## 4.2 Insulation distribution in sTES envelope

Heat losses from sTES systems can eventually dissipate either into the ground-air interface or into the ground [35]. To mitigate these losses, it is essential to consider comprehensive

insulation around the storage envelope – whether a tank or pit. Various insulation distribution configurations are possible, depending on specific requirements. For instance, in some setups, the bottom of the envelope is left uninsulated to allow heat dissipation into the ground, while in cases where groundwater is present, bottom insulation becomes crucial, as shown in Figure 21. This necessity highlights the importance of determining an optimal insulation distribution.

The distribution of insulation within the sTES envelope strongly depends on the system’s location (above-ground/freestanding, partially, or fully buried) and geometry (tank or pit). Key components requiring insulation include the top cover, sidewalls, and bottom. Each of these areas faces unique thermal demands and physical constraints, necessitating tailored insulation strategies.

Figure 21 provides a comparison between homogeneous (option a) and various inhomogeneous (options b-f) insulation distribution configurations over the sTES envelope. These configurations are designed with a focus on both economic feasibility and technical performance, aiming to maintain better stratification while minimising costs.

Despite the different options for the optimum distribution of insulation, it is sometimes recommended to insulate the stratified storage envelope in an inhomogeneous pattern (truncated cone/pyramid-shaped insulation geometries) [36]. In this design, the insulation thickness is greater at the top and gradually decreases with depth, as illustrated in Figure 21(b). The advantage of this pattern is that it provides better insulation for the region where the hot water gathers, while still surrounding the bottom – where cold water is located – with an acceptable thickness of insulation [37]. This approach may lead to lower costs and improved stratification inside the sTES, ultimately resulting in better techno-economic performance as shown in [38].

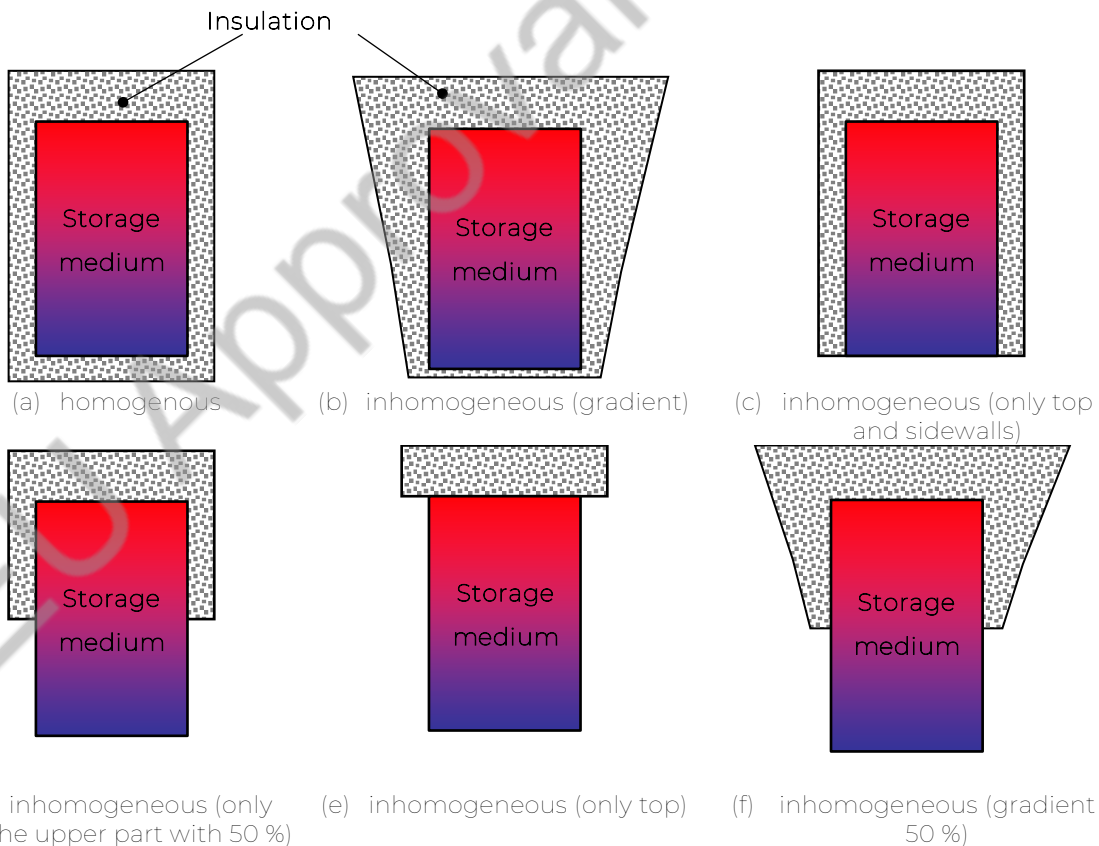

Figure 21: Illustration of several insulation distribution configurations for sTES systems (reproduced from [36]).

### 4.2.1 Top cover insulation

The top cover is the most vulnerable sTES component to heat loss in above-ground and partially buried systems, as it interfaces directly with the external environment. Top-cover insulation typically comprises thick layers of high-performance materials like PUR foam, XPS, or VIPs to minimise thermal bridging. In PTES systems, where floating covers are commonly used, additional insulation layers such as XPS or mineral wool may be added below the floating cover. Trafficable or pedestrian-accessible covers are increasingly used in urban areas, requiring reinforced insulation to support the additional load, typically with materials like XPS or foam glass.

### 4.2.2 Sidewall insulation

Sidewall insulation requirements vary with the depth and surrounding environmental conditions of the sTES system. For above-ground and partially buried systems, sidewall insulation must mitigate both thermal losses and potential moisture penetration (i.e. infiltration). Materials like XPS and PUR foam, which combine low thermal conductivity with moisture resistance, are often used in layered configurations, with vapour barriers or protective fleeces added as needed (see Figure 19 and Figure 20). In cases where VIPs are used, these are often sandwiched between more durable insulation layers to protect against physical damage.

### 4.2.3 Bottom insulation

The bottom layer of sTES systems – especially in buried installations – is frequently the most challenging to insulate due to interactions with groundwater and ground conditions. Often, foam glass or PUR foam is applied in the bottom layer for buried systems, as these materials resist moisture and provide structural stability. In some instances, no insulation is added to the bottom to allow for controlled thermal exchange with the ground, enhancing natural geothermal stability. However, if groundwater temperatures need to be managed, additional insulation may be added along with waterproof membranes.

### 4.2.4 Multi-layered insulation approach

To optimise performance, sTES systems often can incorporate a multi-layered insulation design. For example, combining XPS for structural support and PUR foam or mineral wool for thermal insulation enhances durability while reducing heat loss. Similarly, adding VIPs to sections with the highest heat loss potential, such as top covers or shallow sidewalls, can significantly improve thermal efficiency [6].

## 4.3 Installation techniques of insulation for sTES applications

The design and installation of thermal insulation layers for sTES systems present significant challenges in building physics and thermodynamics [39]. This complexity arises from the need to simultaneously prevent heat conduction and vapor diffusion from the inside to the outside, as well as to inhibit water penetration from the external environment.

Thermal insulation materials are thus available in two primary forms: plates and bulk materials [2]. Insulation plates have the advantage of not requiring complex frames or textile bags to secure the insulating material [40]. However, a notable drawback is that these plates necessitate additional waterproofing measures to ensure their effectiveness against moisture penetration. As a result, bulk materials are often favored for simpler installations. They can be easily filled into prefabricated geotextile bags, achieving both watertightness and thermal insulation in a single step.

Furthermore, vacuum evacuation can enhance the stability of insulation materials by promoting compaction and creating negative pressure, which protects them against humidity [28]. This method also facilitates long-term monitoring through vacuum control.

In all cases, it is essential to avoid thermal bridges through the careful installation of connecting pipes to maintain the overall thermal integrity of the sTES system [1].

## 4.4 Insulation materials for sTES applications

The selection of an appropriate insulation material for sTES is crucial, as it must withstand temperature fluctuations, resist moisture penetration and accumulation, and provide long-term thermal resistance and mechanical stability. Several materials are widely used in sTES insulation.

### 4.4.1 Conventional insulation materials

#### Polyurethane (PUR) foam

Polyurethane foam is a favoured insulation material due to its low thermal conductivity (0.02-0.03 W/(m·K)) [41], and high durability. PUR foam provides effective thermal resistance and can be applied as rigid boards or spray foam, adapting to various sTES shapes and designs. However, PUR foam is sensitive to UV exposure and must be adequately shielded when used in external layers or near the surface. The application of this material found its place favourably for sidewalls and top in sTES.

#### Extruded polystyrene (XPS) and expanded polystyrene (EPS)

Both XPS and EPS offer high thermal resistance (0.03-0.04 W/(m·K)) [28], and moisture resistance, making them popular choices for buried sTES systems. XPS, in particular, has high compressive strength, making it suitable for systems requiring structural support, such as underground or partially buried sTES installations. EPS, in contrast, is lighter and more cost-effective but may absorb more moisture over time, necessitating additional protective layers in wet environments.

#### Mineral wool (rock wool and glass wool)

Mineral wool, including both rock wool and glass wool, is a highly fire-resistant insulation material with thermal conductivity values typically around 0.03-0.04 W/(m·K) [41]. Mineral wool is commonly used in high-temperature applications and offers excellent thermal performance. However, its moisture resistance is lower than that of XPS or PUR foam, making it more suited for dry environments or applications where additional vapor barriers are in place.

#### Polyethylene (PE) foam

Polyethylene (PE) foam is a versatile closed-cell insulation material utilised in sTES applications due to its favourable thermal and mechanical properties. With a thermal conductivity ranging from 0.03 to 0.04 W/(m·K) [39], PE foam effectively minimises heat losses while providing good moisture resistance. Its lightweight and flexible nature facilitates easy installation, allowing for uniform coverage in various sTES geometries. Additionally, PE foam exhibits high mechanical resistance, making it suitable for applications where substantial pressure is exerted, such as at the bottom of sTES systems. However, it is essential to protect PE foam from UV exposure and harsh chemicals to ensure long-term durability.

A main disadvantage of conventional insulating materials is their non-uniform thermal behaviour. Most of these materials have an increasing thermal conductivity with increasing temperature [28]. Thus, their performance might decline leading to more thermal losses to

the environment [1]. Furthermore, it is important to mention that some of these insulation materials impose high specific investment costs leading to costly sTES installations [4]. Thus, natural insulation materials might be a promising alternative. Such materials are pumice, perlite and expanded clay [39].

## 4.4.2 Natural insulation materials

### Perlite

Perlite is a volcanic glass that, when heated, expands to create a lightweight, porous material. It is an effective thermal insulation material with a thermal conductivity ranging from 0.04 to 0.06 W/(m·K) [1]. Perlite is often used as a lightweight aggregate in insulation applications and can be easily combined with other materials to enhance its insulating properties. Its non-combustible nature and resistance to pests make it a desirable option for sustainable sTES systems. Yet, perlite is characterised by low compressive strength impeding its application for sidewalls and bottom of sTES. Besides, it is well-known for its susceptibility to moisture, thus enhancing moisture penetration and accumulation leading to increased thermal conductivity and, consequently, sTES thermal losses.

### Expanded clay

Expanded clay is a lightweight, inorganic insulation material made from clay pellets that have been heated to create a porous structure. It offers good thermal insulation properties, with a thermal conductivity ranging from 0.05 to 0.07 W/(m·K) [38]. Expanded clay is resistant to moisture and has excellent compressive strength, making it suitable for use in the construction of buried sTES systems. Its natural properties also contribute to improved drainage, reducing the risk of water accumulation around the storage system. Despite its lightweight, this natural insulation material is still heavier than many other options affecting the structural design of sTES. It can also absorb moisture over time, potentially impacting insulating performance. Furthermore, it might be more expensive compared to other conventional insulation materials (e.g. EPS).

### Pumice

Pumice is a naturally occurring volcanic rock that has excellent insulating properties due to its lightweight and porous structure. With a thermal conductivity of about 0.060 to 0.080 W/(m·K) [41], pumice is often used in lightweight concrete and as a loose-fill insulation material. Its resistance to moisture and high compressive strength makes it suitable for use in sTES applications, particularly in environments where water intrusion may be a concern. Additionally, pumice is eco-friendly and abundant, contributing to the sustainability of sTES systems. Depending on geographic location, pumice may not be readily available, leading to potential logistical challenges and increased transportation costs.

Next to these natural insulation materials, INTERSTORES also investigates the use of other natural materials such as woodchips, sawdust and coconut fibres as insulation materials. Thus:

### Woodchips

Wood chips are an organic insulation material derived from wood processing. They provide a sustainable option with reasonable thermal insulation properties offering a thermal conductivity of around 0.04 to 0.05 W/(m·K). However, this material can decompose over time leading to reduced insulation performance. It is also susceptible to moisture penetration and accumulation, which can promote thermal conductivity decreasing sTES performance. Moreover, there are several factors (e.g. fibres orientation, compaction, woods source, woods processing) that might severely affect its thermal conductivity leading to a more realistic thermal conductivity ranging between 0.08 and 0.11 W/(m·K). Yet, woodchips are relatively cheaper compared to most of the conventional insulation materials.

### Sawdust

Sawdust, a byproduct of wood processing, can also be utilised as an insulation material. Its availability and low cost make it an attractive option. It provides decent insulation with a thermal conductivity similar to that of the woodchips. However, the compaction of this material might be one of the leading disadvantages impeding its further use for sTES applications. Sawdust can settle over time leading to higher compaction and increasing thermal conductivity, which eventually leads to higher thermal losses. Similar to woodchips, it can absorb moisture, leading to mold growth and reduced thermal performance.

### Coconut fibres

Coconut fibres (coir) are a natural insulation material derived from the husks of coconuts. They are biodegradable and provide reasonable thermal resistance options as they offer a thermal conductivity ranging from 0.04 up to 0.06 W/(m·K). However, it is strongly vulnerable to moisture and, thus, potential material decay and reduced sTES performance. It also lacks the structural strength as that of other insulation materials and, therefore, it impedes its use when structural stability is required. Furthermore, its quality and performance can strongly vary based on the processing methods.

Further advantages of natural materials are the favourable environmental compatibility and often low costs. Therefore, another innovative pillar within the domain of sTES insulation materials is the use of recycled materials such as foam glass (gravel or sheets) and expanded glass gravel as insulations.

## **4.4.3 Recycled insulation materials**

### Foam glass

Foam glass is a lightweight, rigid insulation material made from recycled glass. It has moderate thermal insulation properties, with a thermal conductivity of approximately 0.06 to 0.08 W/(m·K) [6]. Foam glass is also non-combustible and resistant to moisture and chemical degradation, making it suitable for various sTES applications. It is also suitable for load-bearing applications. Yet, it can be prone to cracking if subjected to heavy loads or impacts. Besides, the main drawback of this material is that it is more expensive than conventional insulation materials [4].

### Expanded glass granulates

Expanded glass granulates are produced by heating glass to high temperatures, causing it to expand and form granules. This material offers good thermal insulation properties with a thermal conductivity similar to that of foam glass. This material is characterised with lightweight resulting in ease of transportation and handling. Together with foam glass, they promote sustainability and circular economy as they are both products of recycled materials. It also reduces the risk of moisture-related issues thanks to its low water absorption. Yet, it may not provide the same level of insulation as more specialised materials like PUR foam, PE foam or XPS. Its properties (i.e. thermal properties) can vary based on the manufacturing process.

## 5 Concepts for optimal operation – charging manager

The optimal operation of sTES is vital for balancing energy, enhancing operational efficiency, and minimising costs. At the core of this operation is the **charging manager**, a dedicated control component that manages energy flows within the sTES to achieve these objectives.

Optimal operation of sTES cannot function as a single unit but is part of a broader, interconnected thermal energy network. This network comprises various energy sources, storage units, demand points, and a distribution network that collectively aims to balance energy supply and demand. The sTES system contributes to this balance by absorbing surplus energy during periods of high energy generation or low demand and discharging energy during times of low generation or high demand.

To fully understand the charging manager's role, it's essential to consider the levels of control for the sTES and energy system [42]:

- **Level Zero control:** This upper-level control addresses when to charge or discharge based on information from the energy system's view [43]. It does not focus on storage-specific details such as the exact thermal stratification within the storage tank. Instead, it prioritises system-wide considerations, like ensuring renewable energy is utilised effectively or maintaining grid stability during peak demand periods. By doing so, it aligns sTES operations with the overall network's requirements for efficiency and reliability.
- **Level One control:** At this level, the control is storage-specific, focusing on how best to use energy in the sTES [44]. It manages energy flows internally, at a detailed component level, to maintain thermal stratification, optimise charging/discharging rates, and minimise heat losses. Level One control is essential for ensuring sTES operates efficiently, while Level Zero control is equally critical in aligning sTES operations with the broader energy network.

This chapter focuses on the charging manager's role in achieving optimal sTES operation. The core functions of the charging manager are detailed to explain its responsibilities, which include balancing energy loads, maintaining thermal stratification, optimising the utilisation of available energy sources, and ensuring efficient energy storage and retrieval. These functions define the charging manager's tasks in managing energy flows to meet the specific requirements of the sTES system and the broader energy network.

This chapter also explores control algorithms, which serve as the methods or strategies employed by the charging manager to execute these core functions. These algorithms include rule-based control for straightforward, predefined energy flow management, model predictive control (MPC) for dynamic real-time optimisation, and AI-based approaches for adaptive decision-making under uncertain or rapidly changing conditions.

Key performance indicators (KPIs) are outlined to guide the charging manager's control decisions. Additionally, essential tools such as monitoring and data acquisition systems provide real-time insights into system performance, while user interfaces facilitate operator oversight and adjustments, enabling effective implementation of these control algorithms. Together, these elements ensure the charging manager delivers efficient and reliable sTES operations while maintaining alignment with both system-wide and subsystem-specific goals.

## 5.1 Key tasks of the charging manager

Charging Manager's primary tasks include balancing energy loads, maintaining thermal stratification, and utilising energy sources efficiently. By fulfilling these requirements, the charging manager supports the optimal operation of the sTES.

### 5.1.1 Balancing the load

Load balancing refers to the charging manager's ability to align energy charge and discharge with fluctuating energy demand and supply. This task involves distributing energy usage evenly over time to reduce peaks in demand. The charging manager contributes to grid stability and supports the integration of intermittent renewable energy sources. Load balancing also minimises reliance on backup systems, reducing operational costs and environmental impacts.

### 5.1.2 Maintaining thermal stratification

Thermal stratification refers to the natural layering of hot and cold zones within the storage medium. Maintaining this stratification is crucial for energy efficiency, as it minimises thermal mixing, reduces energy losses, and ensures that energy can be recovered at the desired temperature [42]. Two main concepts of charging and discharging are:

- Serial charging and discharging: Serial operation involves sequentially charging or discharging energy layer by layer. This approach helps maintain a temperature gradient within the storage medium, preserving stratification and ensuring minimal mixing between hot and cold zones. For instance, during charging, high-temperature energy is introduced at the top layers, while low-temperature energy remains undisturbed at the bottom. Similarly, discharging occurs layer by layer, starting from the desired temperature zone.
- Parallel charging and discharging: Parallel operations involve charging or discharging multiple layers simultaneously, often facilitated by separate inlets or outlets at different heights within the storage medium. While this approach allows for faster energy transfer, it requires careful control to avoid disrupting the thermal layers. Parallel operations are particularly useful when high power rates are needed within a short time, but they demand sophisticated control systems to ensure stratification is maintained.

Energy must be introduced or withdrawn at controlled rates to avoid turbulence or mixing within the storage medium. Rapid or unregulated energy transfer can collapse the thermal gradient, leading to inefficiencies. Studies have shown that variable flow control strategies can effectively regulate energy transfer, maintaining stratification and minimising losses [43].

### 5.1.3 Utilising energy sources

The charging manager optimises energy source selection based on availability, cost, and system compatibility. It prioritises renewable sources, such as solar and waste heat, to reduce operational costs and environmental impact [44]. By adapting to energy availability, the charging manager ensures efficient and sustainable storage operations. It evaluates the trade-offs between technical performance and economic feasibility for different energy sources. This involves analysing factors such as:

- Cost efficiency: Selecting energy sources that minimise operational costs without compromising performance.
- Energy availability: Prioritising sources that are readily available, such as waste heat from industrial processes or surplus electricity from renewable energy generation.
- System compatibility: Ensuring the chosen energy source aligns with the technical requirements of the sTES system, such as temperature and flow rate specifications.

For example, waste heat from nearby industrial facilities might offer a low-cost and readily available charging option, whereas using grid electricity during negative price hours might be more cost-effective.

By balancing energy loads, controlling charging and discharging cycles, maintaining thermal stratification, and optimising energy sources, the charging manager plays a central role in achieving efficient storage operations.

## 5.2 Control approaches for charging manager

The charging manager can be based on a variety of control strategies to operate sTES [44]. These strategies differ in complexity, adaptability, and data requirements, enabling the charging manager to manage energy flows efficiently and respond to dynamic system needs [43]. The choice of control method depends on several factors, including the predictability of energy demand and supply, the availability of computational resources, and the desired level of system optimisation [45]. Broadly, these control approaches can be classified into three main categories: rule-based control, model predictive control, and AI-based control. Each approach offers unique advantages and trade-offs, which are suited to specific operational contexts.

### 5.2.1 Rule-based control

Rule-based control is one of the simplest and most commonly used methods for sTES operations. It relies on predefined rules, often derived from historical data, fixed schedules, or operational thresholds to control charging and discharging activities [49]. For example, energy storage may be charged during periods of low demand or surplus renewable energy and discharged during peak demand hours based on a fixed schedule. This approach is easy to implement, requires minimal computational resources, and provides reliable outcomes in systems with predictable energy flows or consistent demand patterns. However, such control lacks the flexibility to adapt to dynamic or unforeseen changes in energy demand or supply and therefore might achieve suboptimal performance [49].

### 5.2.2 Model predictive control

MPC represents a more advanced and dynamic approach to managing sTES operations. Unlike rule-based control, MPC continuously predicts the future system's behavior using mathematical models and real-time data [50]. These predictions account for variables such as energy demand, storage levels, and energy source availability, enabling the charging manager to optimise operations over a defined time horizon [43]. MPC is well-suited for systems with multiple variables and constraints, such as fluctuating renewable energy availability or diverse energy demands. However, it requires accurate models of the system and computational resources to run predictive algorithms, which make the implementation more complex and resource-intensive [43].

### 5.2.3 Model-free approach

The model-free control is the most flexible and adaptive of the three approaches. Unlike rule-based control or MPC, model-free approaches do not rely on predefined rules or explicit models of the system. Instead, they use machine learning algorithms to analyse real-time data and learn from historical performance. Over time, these systems adapt their strategies to optimise charging and discharging operations under varying conditions. It requires significant data, robust training processes, and computational infrastructure. But it is not guaranteed that you reach optimal performance.

These three control approaches offer distinct levels of complexity and adaptability. Rule-based control is ideal for simple, predictable systems, while MPC provides dynamic optimisation for more complex environments. Model-free approaches excel in uncertain and rapidly changing conditions, offering maximum flexibility.

## 5.3 Key performance indicators

The optimal operation of sTES depends on a set of KPIs that guide the charging manager's control decisions. These KPIs provide critical benchmarks for evaluating how well the charging manager aligns its actions with system objectives. By focusing on thermal losses, energy efficiency, storage capacity, response time, and system flexibility, these KPIs ensure that the control strategies employed by the charging manager directly contribute to the optimal operation of the sTES.

### 5.3.1 Thermal losses

Thermal losses occur when heat dissipates to the surroundings from the storage [36]. This KPI evaluates the charging manager's ability to implement strategies that minimise thermal energy dissipation by optimising the state of charge (SOC) [5]. The charging manager ensures that the storage is charged only when there is an upcoming demand, allowing stored energy to be discharged efficiently rather than dissipating unused.

### 5.3.2 Energy efficiency

Energy efficiency represents the ratio of usable energy retrieved from the sTES to the total energy input during charging [6]. Unlike thermal losses, which measure one specific inefficiency, energy efficiency accounts for all factors affecting system performance, including heat loss, poor thermal stratification, control inefficiencies, and energy conversion losses. This KPI is a comprehensive measure of how well the charging manager can store surplus energy from renewable sources and release it when demand peaks [1].

### 5.3.3 Storage capacity

Storage capacity measures the total amount of thermal energy that the sTES can store and release [10]. This KPI directly impacts the system's ability to meet extended periods of demand or accommodate significant volumes of surplus energy. Storage capacity is linked to the operating temperature, as higher temperatures allow for greater energy storage but also introduce challenges such as increased thermal strain on components and higher heat losses [4]. The charging manager must carefully balance these conflicting objectives: maximising storage capacity through high temperatures while minimising strain on the system and mitigating energy losses.

### 5.3.4 Response time

Response time measures how quickly the sTES system can adjust its charging or discharging rates in response to changes in energy demand or supply. A shorter response time indicates that the charging manager is efficiently coordinating with the broader energy system to meet real-time requirements.

### 5.3.5 System flexibility

System flexibility assesses the sTES's ability to adapt to varying operational conditions, including fluctuating renewable energy supply, changing demand, and unexpected grid requirements [46]. This KPI ensures the sTES can dynamically optimise its operations, making it an essential part of a resilient energy network.

## 5.4 Components and tools

The optimal sTES operation relies on essential components and tools that support the charging manager in making precise decisions and managing the system efficiently. These tools enable real-time monitoring of critical parameters and allow operators to interact seamlessly with the system.

**Monitoring and data acquisition:** They are essential for gathering information about how the sTES is working. These systems rely on sensors strategically placed throughout the storage medium and connected components to measure critical parameters such as temperature gradients, energy and mass flow rates, and environmental conditions.

This real-time monitoring ensures that the charging manager can:

- Maintain thermal stratification by monitoring temperature gradients within the storage medium and addressing deviations that could lead to energy inefficiencies [47].
- Optimise charging and discharging processes by observing energy flow rates and ensuring that the sTES operates optimally.
- Identify early signs of potential operational disruptions, such as leaks, equipment malfunctions, or abnormal energy losses, allowing for timely corrective actions [48].
- Update control schedule by taking prediction uncertainties into account.

For example, if sensors detect a loss of thermal stratification, the charging manager can adjust energy flow rates or modify charging strategies to restore the gradient and maintain system efficiency.

**User interface:** This tool connects operators to the sTES system. It provides a centralised platform for monitoring system performance, making operational adjustments, and responding to alerts or notifications.

Key functionalities of the user interface include:

- To view essential metrics such as energy storage levels, temperature distributions, charging and discharging rates, and energy source contributions.
- To allow operators to modify parameters like charging and discharging rates, set priorities for energy source utilisation, or adjust operational schedules based on changing energy demand or supply conditions.

- To alert operators for potential issues, such as deviations from expected performance, abnormal energy losses, or equipment failures.

## 6 Summary and outlook

Seasonal thermal energy storage (sTES) represents a promising solution for enhancing energy efficiency and advancing the transition to sustainable energy systems. With the European Union strongly supporting the integration of renewable energy sources into power grids and thermal networks, sTES has found a crucial role, particularly in district heating and sector coupling. Therefore, **Deliverable 3.4** presents innovative concepts for sTES applications, with a focus on insulation materials, storage media, charging/discharging methods, and optimal operation strategies.

Consequently, **Chapter 2** shifted the focus to the storage medium, which is a critical factor in determining the capacity and efficiency of sTES systems in bridging the gap between energy supply and demand. Particular attention was given to innovative mixtures of filling materials (e.g., sand/gravel/crushed rock) that enhance circularity and sustainability. The chapter also explored the potential of reusing excavated materials and introduced phase change materials (PCMs) as an option to further increase storage capacity.

Then, **Chapter 3** gave insights into the charging and discharging devices, given their importance for sTES performance and response times. It provided a detailed review of direct and indirect methods, including advanced heat exchanger designs and the integration of thermochemical materials (TCMs) and PCMs. The chapter also emphasised the potential of combining direct and indirect methods to improve heat transfer and system efficiency.

**Chapter 4** explored innovative concepts for sTES envelope design, with special attention to insulation materials and their distribution within the storage system. The deliverable highlighted the distinct insulation requirements for the top, sidewalls and bottom of the sTES envelope and briefly reviewed state-of-the-art installation techniques. Insulation materials were categorised into conventional, recycled and natural options, emphasising advancements in using recycled and natural materials to promote circular economy practices and sustainability.

Finally, **Chapter 5** presented concepts for optimal sTES operation, focusing on the "Charging Manager" as a key innovation developed within the INTERSTORES project. This manager is designed to optimise the charging and discharging of sTES systems. The chapter outlined the main tasks of the Charging Manager, the approaches used in its development and the key performance indicators (KPIs) that ensure optimal operation. These elements collectively contribute to improved evaluation and management of sTES systems.

In closing, **Deliverable 3.4** provided a comprehensive examination of cutting-edge sTES concepts, addressing key aspects such as materials, methods, and management systems. The insights presented pave the way for more efficient, sustainable and modular sTES applications, aligning with the EU's renewable energy goals and broader sustainability objectives.

## 7 References

- [1] A. Dahash, F. Ochs, M. Bianchi Janetti and W. Streicher, “Advances in seasonal thermal energy storage for solar district heating applications: A critical review on large-scale hot-water tank and pit thermal energy storage systems,” *Applied Energy*, vol. 239, pp. 296-315, 2019.
- [2] C. Bott, I. Dressel and P. Bayer, “State-of-technology review of water-based closed seasonal thermal energy storage systems,” *Renewable and Sustainable Energy Reviews*, vol. 113, 2019.
- [3] H. Lund, P. A. Østergaard, M. Chang, S. Werner, S. Svendsen, P. Sorknaes, J. Eric Thorsen, F. Hvelplund, B. O. G. Mortensen, B. Vad Mathiesen, C. Bojesen, N. Duic, X. Zhang and B. Möller, “The status of 4th generation district heating: Research and results,” *Energy*, vol. 164, pp. 147-159, 2018.
- [4] A. Dahash, F. Ochs and A. Tosatto, “Techno-economic and exergy analysis of tank and pit thermal energy storage for renewables district heating systems,” *Renewable Energy*, pp. 1358-1379, 2021.
- [5] A. Dahash, F. Ochs, G. Giuliani and A. Tosatto, “Understanding the Interaction between Groundwater and Large-Scale Underground Hot-Water Tanks and Pits,” *Sustainable Cities and Society*, vol. 71, 2021.
- [6] A. Dahash, F. Ochs and A. Tosatto, “Techno-Economic Planning and Exergy Analysis of Large-Scale Hot-Water Tank and Pits,” in *Proceedings of the International Renewable Energy Storage Conference 2021 (IRES 2021)*, 2022.
- [7] S. Koochi-Fayegh and M.A. Rosen, “A review of energy storage types, applications and recent developments,” *Journal of Energy Storage*, vol. 27, 2020.
- [8] L. G. Socaciu, “Seasonal Sensible Thermal Energy Storage Solutions,” *Leonardo Electronic Journal of Practices and Technologies*, no. 19, pp. 49-68, 2011.
- [9] A. Hesaraki, S. Holmberg and F. Haghghat, “Seasonal thermal energy storage with heat pumps and low temperatures in building projects—A comparative review,” *Renewable and Sustainable Energy Reviews*, vol. 43, pp. 1199-1213, 2015.
- [10] A. V. Novo, J. R. Bayon, D. Castro-Fresno and J. Rodriguez-Hernandez, “Review of seasonal heat storage in large basins: Water tanks and gravel–water pits,” *Applied Energy*, vol. 87, no. 2, pp. 390-397, 2010.
- [11] R. Marx, J. Nußbicker-Lux, D. Bauer, W. Heidemann and H. Drück, “Saisonale Wärmespeicher – Bauarten, Betriebsweise und Anwendungen,” *Chemie Ingenieur Technik*, vol. 83, pp. 1994-2001, 2011.
- [12] C. Bott, M. Ehrenwirth, C. Trinkl and P. Bayer, “Component-based modeling of ground-coupled seasonal thermal energy storages,” *Applied Thermal Engineering*, vol. 214, 2022.

- [13] F. Ochs, W. Heidemann, H. Müller-Steinhagen and H. Koch, "Erdreich/Wasser-Erdbecken-Wärmespeicher mit direktem Beladesystem," in *OTTI 16. Symposium Thermische Solarenergie*, Bad Staffelstein, Germany, 2006.
- [14] T. Urbaneck, "Berechnung des thermischen Verhaltens von Kies-Wasser-Speichern, Ph.D. Dissertation," Shaker Verlag, Aachen, 2004.
- [15] M. Benner, M. Bodmann, D. Mangold, J. Nußbicker, S. Raab, T. Schmidt and H. Seiwald, "Solar unterstützte Nahwärmeversorgung mit und ohne Langzeit-Wärmespeicher: Forschungsbericht zum BMBF/BMWA-Vorhaben," Stuttgart, Germany, 2003.
- [16] D. Mangold, "Seasonal storage – a German success story," *Sun & Wind Energy*, no. 1, pp. 48-58, 2007.
- [17] C. Bott, I. Dressel and P. Bayer, "Seasonal heat storage systems: Present state of large-scale closed systems in Europe," *Geophysical Research Abstracts*, vol. 21, p. 2019.
- [18] C. Bott, D. Hoffmann, C. Trinkl, T. Schrag, S. Müller, M. Faigl, R. Strobel and P. Bayer, "The IN-Campus: A lighthouse site for re-used infrastructures as seasonal thermal energy storage," in *Proceedings of the 16th IEA ES TCP International Conference on Energy Storage (ENERSTOCK 2024)*, Lyon, France, 2024.
- [19] C. Bott and P. Bayer, "Modeling multi-basin water-gravel thermal energy storages with STORE," in *Proceedings of the 16th IEA EST CP International Conference on Energy Storage (Enerstock 2024)*, Lyon, France, 5-7 June 2024.
- [20] C. Bott, M. Noethen, A. Dahash and P. Bayer, "Thermische Auswirkungen großskaliger, geschlossener, saisonaler Kies-Wasser-Speicher," in *Poster presented at the Tagung der Fachsektion Hydrogeologie e.V. in der DGGV e.V.*, Aachen, Germany, 2024.
- [21] M. Bodmann, H. Koch and M. Pfeil, "Solare Nahwärmeversorgung mit Kies/Wasser-Wärmespeicher in Steinfurt-Borghorst," in *OPET-Seminar Solar unterstützte Nahwärme*, Neckarsulm, Germany, 2001.
- [22] C. Bott, A. Dahash, M. Noethen and P. Bayer, "Influence of thermal energy storage basins on the subsurface and shallow groundwater," *Journal of Energy Storage*, vol. 92, 2024.
- [23] C. Bott, M. Ehrenwirth, C. Trinkl, T. Schrag and P. Bayer, "Simulation of Re-Used Basin Structures for Long-Term, Large-Scale Sensible Thermal Energy Storage," in *EGU General Assembly 2023*, Vienna, Austria, 24-28 April 2023.
- [24] A. Dyrelund, "4TH generation district energy: The backbone of liveable and resilient campuses and cities," in *IEA EBC Annex 73 Symposium*, Washington DC, USA, 5-6 December 2017.
- [25] I. Dressel, C. Bott and P. Bayer, "Converting idle infrastructure to large scale seasonal heat storage systems," in *45th International Association of Hydrogeologists Congress*, Daejeon, Korea, 9-14 September 2018.
- [26] M. Riegger and D. Mangold, "Planungsoptimierung und Bau des solaren Nahwärmesystems mit saisonalem Kies-Wasser-Wärmespeicher in

Eggenstein-Leopoldshafen,” in *OTTI: Symposium Thermische Solarenergie*, Bad Staffelstein, Germany, 23-25 May 2008.

- [27] C. Bott, I. Dressel and P. Bayer, “Paraffin wax as self-sealing insulation material of seasonal sensible heat storage systems-A laboratory study,” *PLoS One*, vol. 15, no. 7, 2020.
- [28] W. Villasmil, L. J. Fischer and J. Worlitschek, “A review and evaluation of thermal insulation materials and methods for thermal energy storage systems,” *Renewable and Sustainable Energy Reviews*, vol. 103, pp. 71-84, 2019.
- [29] C. Bott, P. Bayer and I. Dressel, “Closed, in-ground, water-based seasonal storage systems for thermal energy – State of technology in Europe,” in *World Geothermal Congress*, Reykjavik, Iceland, 2020.
- [30] A. L. Nash, A. Badithela and N. Jain, “Dynamic modeling of a sensible thermal energy storage tank with an immersed coil heat exchanger under three operation modes,” *Applied Energy*, vol. 195, pp. 877-889, 2017.
- [31] L. Li, Q. Tang, X. Chen and C. Weng, “Polymer-based pin-fin microchannel heat exchangers: A comparative study of material and structural effects on performance,” *International Journal of Thermal Sciences*, vol. 209, 2025.
- [32] K. Soni and N. Lal Panwar, “Revolutionizing thermal energy storage: An overview of porous support materials for advanced composite Phase Change Materials (PCMs),” *Progress in Engineering Science*, vol. 1, no. 4, 2024.
- [33] A. El Majd, S. Sair, H. Ait Ousaleh, U. Berardi, K. Moulakhnif, N. Belouaggadia, Z. Younsi and A. El Bouari, “Advancing PCM research in building efficiency: A comprehensive investigation into PCM selection and critical integration strategies,” *Journal of Building Engineering*, vol. 96, 2024.
- [34] K. Masera, H. Tannous, V. Stojceska and S. Tassou, “An investigation of the recent advances of the integration of solar thermal energy systems to the dairy processes,” *Renewable and Sustainable Energy Reviews*, vol. 172, 2023.
- [35] E. Nilsson and P. Rohdin, “Performance evaluation of an industrial borehole thermal energy storage (BTES) project – Experiences from the first seven years of operation,” *Renewable Energy*, vol. 143, pp. 1022-1034, 2019.
- [36] A. Dahash, F. Giordano and A. Serageldin, “Enhancing efficiency and feasibility of large-scale thermal energy storage in district heating,” in *Proceedings of BauSim Conference 2024: 10th Conference of IBPSA-Germany and Austria*, Vienna, Austria, 23-26 September 2024.
- [37] B. Kurşun, “Thermal stratification enhancement in cylindrical and rectangular hot water tanks with truncated cone and pyramid shaped insulation geometry,” *Solar Energy*, vol. 169, pp. 512-525, 2018.
- [38] A. Dahash, “Enhancing efficiency and feasibility of large-scale thermal energy storage in district heating,” in *Proceedings of BauSIM 2024*, Vienna, Austria, 2024.

- [39] F. Ochs, Modelling Large-Scale Thermal Energy Stores, Ph.D. Dissertation, Stuttgart: Shaker Verlag, 2009.
- [40] F. Ochs, W. Heidemann and H. Müller-Steinhagen, "Performance of Large-Scale Seasonal Thermal Energy Stores," *Journal of Solar Energy Engineering*, vol. 131, no. 4, 2009.
- [41] F. Ochs, A. Zottl, M. Lauermann, H. Schranzhofer, C. Halmdienst and D. Reiterer, "Store4Grid: Optimierte Erdbecken-Wärmespeicher für Wärmenetze," Klima- und Energiefonds, 2015.
- [42] R. J. Auvil, HVAC Control Systems, vol. 4, Amer Technical Pub, 2017, p. 576.
- [43] M.Z. Pomianowski, H. Johra, A. Marszal-Pomianowska and C. Zhang, "Sustainable and energy-efficient domestic hot water systems: A review," *Renewable and Sustainable Energy Reviews*, vol. 128, 2020.
- [44] R. De Coninck, R. Baetens, D. Saelens, A. Woyte and L. Helsen, "Rule-based demand-side management of domestic hot water production with heat pumps in zero energy neighbourhoods," *Journal of Building Performance Simulation*, vol. 7, no. 4, pp. 271-288, 2014.
- [45] Y. Bai, M. Yang, Z. Wang, X. Li, Xiaoxia and L. Chen, "Thermal stratification in a cylindrical tank due to heat losses while in standby mode," *Solar Energy*, vol. 185, p. 222–234, 2019.
- [46] X. Li, Z. Wang, J. Li, M. Yang, G. Yuan, Y. Bai, L. Chen, T. Xu and A. Gilmanova, "Comparison of control strategies for a solar heating system with underground pit seasonal storage in the non-heating season," *Journal of Energy Storage*, vol. 26, 2019.
- [47] D.-I. Stanica, M. Bachmann and M. Kriegel, "Design and performance of a multi-level cascading district heating network with multiple prosumers and energy storage," *Energy Reports*, vol. 7, pp. 128-139, 2021.
- [48] Y. Zhou, C. Min, K. Wang, L. Xie and Y. Fan, "Optimization of integrated energy systems considering seasonal thermal energy storage," *Journal of Energy Storage*, vol. 71, 2023.
- [49] J. Tarragona, A. L. Pisello, C. Fernández, A. de Gracia and L. F. Cabeza, "Systematic review on model predictive control strategies applied to active thermal energy storage systems," *Renewable and Sustainable Energy Reviews*, vol. 149, 2021.
- [50] J. Tarragona, A. de Garcia and L. F. Cabeza, "Bibliometric analysis of smart control applications in thermal energy storage systems. A model predictive control approach," *Journal of Energy Storage*, vol. 32, 2020.
- [51] A. Ghilardi, G. Francesco Frate, K. Kyrianiadis, M. Tucci and L. Ferrari, "Brayton pumped thermal energy storage: Optimal dispatchment in multi-energy districts," *Energy Conversion and Management*, vol. 314, 2024.
- [52] X. Li, S. Yilmaz, M. K. Patel and J. Chambers, "Techno-economic analysis of fifth-generation district heating and cooling combined with seasonal borehole thermal energy storage," *Energy*, vol. 285, 2023.

- [53] B. Leong Choo and Y. li Go, “Energy storage for large scale/utility renewable energy system - An enhanced safety model and risk assessment,” *Renewable Energy Focus*, vol. 42, pp. 79-96, 2022.

EU Approval Pending



MARTIN-LUTHER-UNIVERSITÄT  
HALLE-WITTENBERG



Funded by the European Union. Views and opinions expressed are however those of the author(s) only and do not necessarily reflect those of the European Union or the European Climate, Infrastructure and Environment Executive Agency (CINEA). Neither the European Union nor the granting authority can be held responsible for them.

Project funded by

 Schweizerische Eidgenossenschaft  
Confédération suisse  
Confederazione Svizzera  
Confederaziun svizra

Swiss Confederation

Federal Department of Economic Affairs,  
Education and Research EAER  
State Secretariat for Education,  
Research and Innovation SERI



Funded by  
the European Union